



Globe valve actuators
SVC 05.1 – SVC 07.5
SVCR 05.1 – SVCR 07.5
with integral actuator controls

Control
→ Parallel
Profibus DP
Modbus RTU



Read operation instructions first.

- Observe safety instructions.
- These operation instructions are part of the product.
- Retain operation instructions during product life.
- Pass on instructions to any subsequent user or owner of the product.

Purpose of the document:

This document contains information for installation, commissioning, operation and maintenance staff. It is intended to support device installation and commissioning.

Reference documents:

Reference documents can be downloaded from the Internet (www.auma.com) or ordered directly from AUMA (refer to <Addresses>).

Table of contents		Page
1.	Safety instructions.....	4
1.1.	Basic information on safety	4
1.2.	Range of application	4
1.3.	Applications in Ex zone 22 (option)	5
1.4.	Warnings and notes	5
1.5.	References and symbols	6
2.	Identification.....	7
2.1.	Name plate	7
2.2.	Short description	8
3.	Transport, storage and packaging.....	10
3.1.	Transport	10
3.2.	Storage	10
3.3.	Packaging	10
4.	Assembly.....	11
4.1.	Mounting position	11
4.2.	Ball handle to handwheel: fit	11
4.3.	Actuator: mount to valve	11
4.3.1.	Actuator for assembly: prepare	11
4.3.2.	Output drive for coupling	12
4.3.2.1.	Mounting with coupling	12
5.	Electrical connection.....	14
5.1.	Basic information	14
5.2.	Connection via screw-type connector	15
5.2.1.	Cable connection	16
5.3.	Connection via bayonet connector	17
5.3.1.	Cable connection	17
5.4.	Connection with AUMA plug/socket connector	18
5.4.1.	Terminal compartment: open	18
5.4.2.	Cable connection	19
5.4.3.	Terminal compartment: close	20
5.5.	Earth connection, external	20
5.6.	Accessories for electrical connection	21

5.6.1.	Local controls mounted on wall bracket	21
6.	Indications	22
6.1.	Mechanical position indicator/running indication	22
6.2.	Indication lights	22
7.	Signals	24
7.1.	Output contacts (binary)	24
7.2.	Analogue signals	24
8.	Operation	25
8.1.	Manual operation	25
8.2.	Motor operation	25
8.2.1.	Local actuator operation	25
8.2.2.	Actuator operation from remote	26
9.	Commissioning (basic settings of controls)	28
9.1.	Cover to controls: open	28
9.2.	Setting via hardware (switches) or via software	28
9.3.	Type of seating: set	29
9.4.	Torque switching: set	30
9.5.	Output speed: set	31
9.6.	Cover to controls: close	32
10.	Commissioning (basic settings at actuator)	34
10.1.	End position detection: verify setting	34
10.2.	End position detection: set again via local controls	34
10.2.1.	End position CLOSED: set again	35
10.2.2.	End position OPEN: set again	35
10.3.	Switch compartment: open	36
10.4.	Potentiometer setting	36
10.5.	Mechanical position indicator: set	38
10.6.	Switch compartment: close	38
11.	AUMA CDT software (accessories)	40
12.	Corrective action	41
12.1.	Fault indications and warning indications	41
12.2.	Fuses	42
12.2.1.	Fuses within the actuator controls	42
12.2.2.	Motor protection (thermal monitoring)	42
13.	Servicing and maintenance	43
13.1.	Preventive measures for servicing and safe operation	43
13.2.	Maintenance	43
13.3.	Disposal and recycling	43
14.	Technical data Globe valve actuator	44
15.	Spare parts	47
15.1.	Globe valve actuator SVC 05.1 – SVC 07.5 / SVCR 05.1 – SVCR 07.5	47
16.	Certificates	49
16.1.	Declaration of Incorporation and EC Declaration of Conformity	49
	Index	52
	Addresses	54

1. Safety instructions

1.1. Basic information on safety

Standards/directives	<p>AUMA products are designed and manufactured in compliance with recognised standards and directives. This is certified in a Declaration of Incorporation and an EC Declaration of Conformity.</p> <p>The end user or the contractor must ensure that all legal requirements, directives, guidelines, national regulations and recommendations with respect to assembly, electrical connection, commissioning and operation are met at the place of installation.</p>
Safety instructions/warnings	<p>All personnel working with this device must be familiar with the safety and warning instructions in this manual and observe the instructions given. Safety instructions and warning signs on the device must be observed to avoid personal injury or property damage.</p>
Qualification of staff	<p>Assembly, electrical connection, commissioning, operation, and maintenance must be carried out exclusively by suitably qualified personnel having been authorised by the end user or contractor of the plant only.</p> <p>Prior to working on this product, the staff must have thoroughly read and understood these instructions and, furthermore, know and observe officially recognised rules regarding occupational health and safety.</p>
Commissioning	<p>Prior to commissioning, it is important to check that all settings meet the requirements of the application. Incorrect settings might present a danger to the application, e.g. cause damage to the valve or the installation. The manufacturer will not be held liable for any consequential damage. Such risk lies entirely with the user.</p>
Operation	<p>Prerequisites for safe and smooth operation:</p> <ul style="list-style-type: none"> • Correct transport, proper storage, mounting and installation, as well as careful commissioning. • Only operate the device if it is in perfect condition while observing these instructions. • Immediately report any faults and damage and allow for corrective measures. • Observe recognised rules for occupational health and safety. • Observe the national regulations. • During operation, the housing warms up and surface temperatures > 60 °C may occur. To prevent possible burns, we recommend checking the surface temperature using an appropriate thermometer and wearing protective gloves, if required, prior to working on the device.
Protective measures	<p>The end user or the contractor are responsible for implementing required protective measures on site, such as enclosures, barriers, or personal protective equipment for the staff.</p>
Maintenance	<p>To ensure safe device operation, the maintenance instructions included in this manual must be observed.</p> <p>Any device modification requires prior consent of the manufacturer.</p>

1.2. Range of application

AUMA globe valve actuators are designed for the operation of valves.
Other applications require explicit (written) confirmation by the manufacturer.

The following applications are not permitted, e.g.:

- Industrial trucks according to EN ISO 3691
- Lifting appliances according to EN 14502
- Passenger lifts according to DIN 15306 and 15309
- Service lifts according to EN 81-1/A1
- Escalators

- Buried service
- Continuous submersion (observe enclosure protection)
- Potentially explosive atmospheres
- Radiation exposed areas in nuclear power plants

No liability can be assumed for inappropriate or unintended use.

Observance of these operation instructions is considered as part of the device's designated use.

Information These operation instructions are only valid for the "clockwise closing" standard version, i.e. driven shaft turns clockwise to close the valve.

1.3. Applications in Ex zone 22 (option)

Actuators of category Ex II3D basically meet the requirements for applications in dust hazardous locations of ZONE 22 in compliance with the ATEX directive 94/9/EC.

Actuators for zone 22 are at least designed in enclosure protection IP65 and comply with the provisions of IEC 60079-0 - Explosive atmospheres - Part 0: Equipment - General requirements.

To comply with all requirements of IEC 60079-0, it is imperative that the following points are observed:

- In compliance with the ATEX directive 94/9/EC, the actuators must be equipped with an additional identification – II3D IP6X T150 °C.
- The maximum surface temperature of the actuators, based on an ambient temperature of +70 °C in accordance with IEC 60079-0 section 5.3, is +150 °C. In accordance with section 5.3.2, an increased dust deposit on the equipment was not considered for the determination of the maximum surface temperature.
- Fulfilling the requirements of the duty type and the technical data are prerequisites for compliance with the maximum surface temperature of devices.
- The connectors may only be connected or disconnected when not live.
- The cable glands used also have to meet the requirements of category II3 D and must at least comply with enclosure protection IP67.
- The actuators must be connected by means of an external earth connection to the equipotential earth bonding or integrated into an earthed piping system.
- As a general rule, the requirements of IEC 60079-0 and EN 13463-1 must be respected in dust hazardous locations. During commissioning, service, and maintenance, special care as well as qualified and trained personnel are required for the safe operation of actuators.
- Connectors and components remaining live when not connected to a socket are not permissible.

1.4. Warnings and notes

The following warnings draw special attention to safety-relevant procedures in these operation instructions, each marked by the appropriate signal word (DANGER, WARNING, CAUTION, NOTICE).



Indicates an imminently hazardous situation with a high level of risk. Failure to observe this warning could result in death or serious injury.



Indicates a potentially hazardous situation with a medium level of risk. Failure to observe this warning could result in death or serious injury.



Indicates a potentially hazardous situation with a low level of risk. Failure to observe this warning may result in minor or moderate injury. May also be used with property damage.

NOTICE

Potentially hazardous situation. Failure to observe this warning may result in property damage. Is not used for personal injury.

Arrangement and typographic structure of the warnings**DANGER****Type of hazard and respective source!**

Potential consequence(s) in case of non-observance (option)

- Measures to avoid the danger
- Further measure(s)

Safety alert symbol  warns of a potential personal injury hazard.

The signal word (here: DANGER) indicates the level of hazard.

1.5. References and symbols

The following references and symbols are used in these instructions:

Information The term **Information** preceding the text indicates important notes and information.

 Symbol for CLOSED (valve closed)

 Symbol for OPEN (valve open)

✓ Important information before the next step. This symbol indicates what is required for the next step or what has to be prepared or observed.

< > Reference to other sections

Terms in brackets shown above refer to other sections of the document which provide further information on this topic. These terms are either listed in the index, a heading or in the table of contents and may quickly be found.

2. Identification

2.1. Name plate

Figure 1: Arrangement of name plates

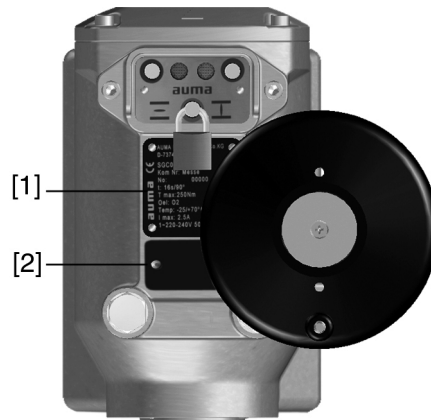

- [1] Actuator name plate
- [2] Additional plate, e.g. KKS plate (Power Plant Classification System)

Description of actuator name plate

Figure 2: Actuator name plate (example)

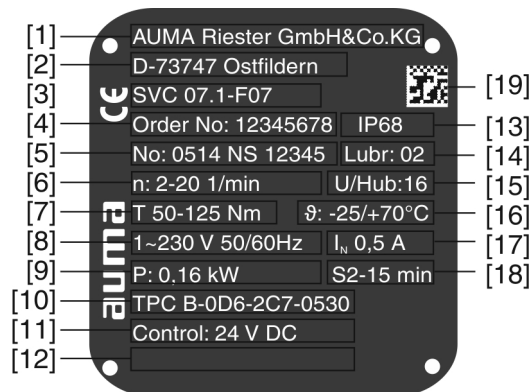

- [1] Name of manufacturer
- [2] Address of manufacturer
- [3] **Type designation**
- [4] **Order number**
- [5] **Actuator serial number**
- [6] Speed
- [7] Torque range
- [8] Current type, mains voltage, mains frequency
- [9] Electric power (motor)
- [10] Wiring diagram number
- [11] **Control**
- [12] Can be assigned as an option upon customer request
- [13] Enclosure protection
- [14] Type of lubricant
- [15] Turns per stroke
- [16] Permissible ambient temperature
- [17] Rated current
- [18] Type of duty
- [19] **Data Matrix code**

Type designation Figure 3: Type designation (example)

SVC 07.1-F07

1. 2.

1. Type and size of actuator
2. Flange size

Type and size

These instructions apply to the following devices types and sizes:

Globe valve actuators for open-close duty: SVC 05.1, 07.1, 07.5

Globe valve actuators for modulating duty: SVCR 05.1, 07.1, 07.5

Order number The product can be identified using this number and the technical data as well as order-related data pertaining to the device can be compiled.

Please always state this number for any product inquiries.

On the Internet at <http://www.auma.com>, we offer a service allowing authorised users to download order-related documents such as wiring diagrams and technical data (both in German and English), inspection certificates and the operation instructions when entering the order number.

Actuator serial number Table 1: Description of serial number (with example)

05	14	NS12345
1st + 2nd position: Assembly in week		
05	Week 05	
3rd + 4th position: Year of manufacture		
	14	Year of manufacture: 2014
All other positions		
		NS12345 Internal number for unambiguous product identification

Control **24 V DC** = Control via parallel interface at 24 V DC control voltage.

0/4 – 20 mA = Control via parallel interface via analogue input 0/4 – 20 mA.

Data Matrix code When registered as authorised user, you may use the **AUMA Support App** to scan the Data Matrix code and directly access the order-related product documents without having to enter order number of serial number.

Figure 4: Link to the App store:



2.2. Short description

Globe valve actuator AUMA globe valve actuators are multi-turn actuators for the automation of globe valves and are driven by an electric motor. For control in motor operation and for processing the actuator signals, controls are integrated within the housing. The actuator can be operated easily on site via the local controls. A handwheel or crank is provided for manual operation. Manual operation is possible without change-over.

Switching off in end positions may be either by limit or torque seating.

As for part-turn actuators, the connection dimensions of AUMA globe valve actuators are designed according to EN ISO 5211.

AUMA CDT The AUMA CDT software (accessories) can be used to establish a connection to a computer (PC, laptop or PDA). Among others, the software can be used to read in and out data and to save and modify settings.

The connection between computer and the integral actuator controls is made using a service cable.

3. Transport, storage and packaging

3.1. Transport

For transport to place of installation, use sturdy packaging.



Hovering load!

Risk of death or serious injury.

- Do NOT stand below hovering load.
- Attach ropes or hooks for the purpose of lifting by hoist only to housing and NOT to handwheel.
- Actuators mounted on valves: Attach ropes or hooks for the purpose of lifting by hoist to valve and NOT to actuator.

3.2. Storage



Danger of corrosion due to inappropriate storage!

- Store in a well-ventilated, dry room.
- Protect against floor dampness by storage on a shelf or on a wooden pallet.
- Cover to protect against dust and dirt.
- Apply suitable corrosion protection agent to uncoated surfaces.

Long-term storage

If the device must be stored for a long period (more than 6 months) the following points must be observed in addition:

1. Prior to storage:
Protect uncoated surfaces, in particular the output drive parts and mounting surface, with long-term corrosion protection agent.
2. At an interval of approx. 6 months:
Check for corrosion. If first signs of corrosion show, apply new corrosion protection.

Plastic protective caps supplied when leaving the factory are for transport protection only. They have to be replaced for long-term storage. (Heed protection type indicated on name plate.)

3.3. Packaging

Our products are protected by special packaging for transport when leaving the factory. The packaging consists of environmentally friendly materials which can easily be separated and recycled. We use the following packaging materials: wood, cardboard, paper, and PE foil. For the disposal of the packaging material, we recommend recycling and collection centres.

4. Assembly

4.1. Mounting position

AUMA actuators can be operated without restriction in any mounting position.

4.2. Ball handle to handwheel: fit

To avoid damage during transport, the ball handle is fitted at the rear of the handwheel.

Prior to commissioning, mount the ball handle into correct position:

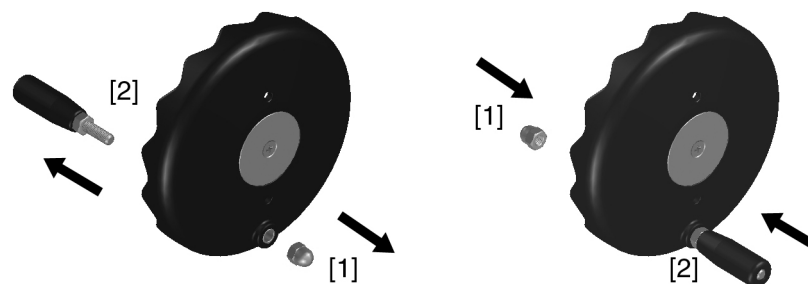

1. Remove cap nut [1] and pull out ball handle [2].
2. Insert ball handle [2] in correct position and fasten with cap nut [1].

Information The end position detection can be modified by turning the handwheel while actuator is not mounted to a valve. Therefore, we recommend not to turn the handwheel prior to mounting to the actuator to the valve.

4.3. Actuator: mount to valve

4.3.1. Actuator for assembly: prepare

Prior to mounting, both valve and actuator must be in the same end position!

- For butterfly valves, the recommended mounting position is end position CLOSED.
- For ball valves, the recommended mounting position is end position OPEN.

In compliance with the order, the actuator is supplied either in position CLOSED or position OPEN. The mechanical position indicator supplies information on the set position.

If the actuator position was not modified and agrees with the valve position, the actuator can be mounted in the supplied position.

In case the actuator is in an incorrect position:

1. Operate the actuator into the same position as the valve via push buttons OPEN, STOP, CLOSE while in motor operation. For motor operation, please refer to <Actuator operation at the local controls> chapter.
2. Should the electrical connection not be available at the time of assembly, the actuator can be operated into the required end position using the handwheel.
 - 2.1 Turn the handwheel or the crank handle until the respective symbol (OPEN/CLOSED) of mechanical position indication corresponds to the mark (same end position OPEN or CLOSED as valve).

Information: Since the actuator is not equipped with internal end stops (mechanical limits), the symbol should not be turned ahead of the mark.
 - 2.2 Turn handwheel by approximately two turns (overrun) in the opposite direction.

After this procedure, the actuator can be mounted to the valve.

4.3.2. Output drive for coupling

- Application**
- For valves with output drive types according to EN ISO 5211
 - Capable of withstanding thrust
- Assembly**
- The actuator is mounted to the valve using a coupling placed onto the valve shaft.
 - Unbored couplings must be adapted and machined to match the valve shaft prior to mounting (e.g. with bore and keyway, two-flat or square bore)

Figure 5: Coupling variants

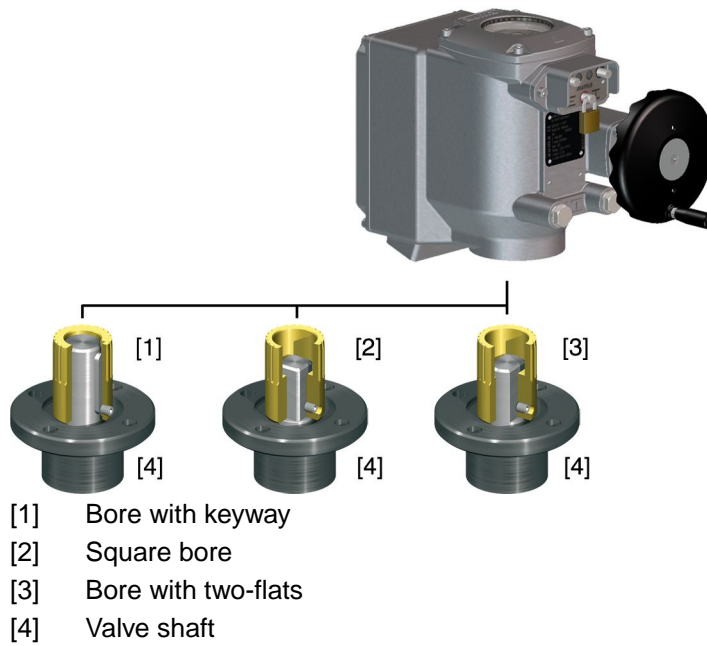

4.3.2.1. Mounting with coupling

Condition: Valve and actuator are in the same end position.

Figure 6: Coupling fitting dimensions

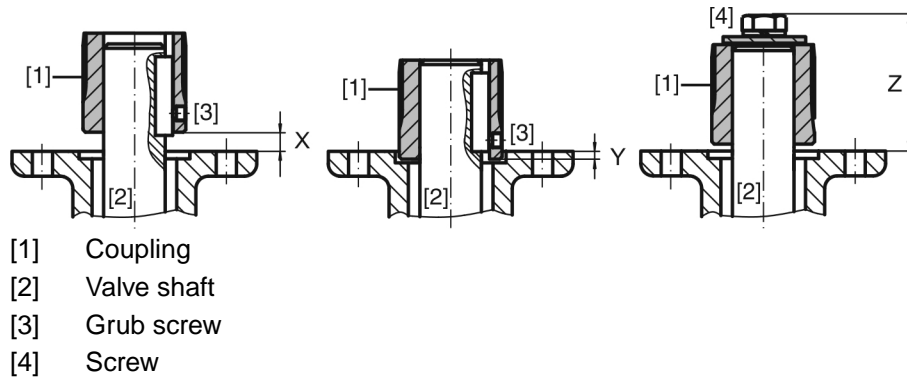

Table 2: Coupling fitting dimensions

Type, size - output mounting flange	X max [mm]	Y max [mm]	Z max [mm]
SVC/SVCR 05.1-F07	2.5	6	40
SVC/SVCR 07.1-F07	2.5	6	50
SVC/SVCR 07.5-F07	2.5	6	50

1. Thoroughly degrease mounting faces of output mounting flanges.
2. Apply a small quantity of grease to the valve shaft [2].

3. Place coupling [1] onto valve shaft [2] and secure against axial slipping by using a grub screw [3], a circlip or a screw [4]. Thereby, ensure that dimensions X, Y or Z are observed (refer to figure and table <Coupling fitting dimensions>).
4. Apply non-acidic grease at splines of coupling.
5. Fit actuator.

Information: Ensure that the spigot (if provided) fits uniformly in the recess and that the flanges are in complete contact.

6. If flange bores do not match thread:
 - 6.1 Slightly rotate handwheel until bores line up.
 - 6.2 If required, shift actuator position by one tooth on the coupling.
7. Fasten actuator with screws [4].

Information: We recommend applying liquid thread sealing material to the screws to avoid contact corrosion.

→ Fasten screws [4] crosswise with a torque according to table.

Table 3: Tightening torques for screws

Screws Threads	Tightening torque T_A [Nm]
	Strength class A4-80
M8	24

5. Electrical connection

5.1. Basic information



Danger due to incorrect electrical connection

Failure to observe this warning can result in death, serious injury, or property damage.

- The electrical connection must be carried out exclusively by suitably qualified personnel.
- Prior to connection, observe basic information contained in this chapter.
- After connection but prior to applying the voltage, observe the <Commissioning> and <Test run> chapters.

Wiring diagram/terminal plan

The pertaining wiring diagram/terminal plan (both in German and English) is attached to the device in a weather-proof bag, together with these operation instructions. It can also be requested from AUMA (state order number, refer to name plate) or downloaded directly from the Internet (<http://www.auma.com>).

Permissible networks (supply networks)

The actuators are suitable for use in TN and TT networks with directly earthed star point. Use in IT networks is permitted while observing the respective <Protection on site>.

Protection on site

For short-circuit protection and for disconnecting the actuator from the mains, fuses and disconnect switches have to be provided by the customer.

The current value for respective sizing is derived from the current consumption of the actuator (refer to electrical data sheet).

The actuators are suitable for use in current circuits with a maximum short-circuit 1-phase AC current value of 5,000 A root-mean-square (R.M.S). The output data of the fuses to be provided on site must not exceed the following values: 15 A/250 V at a maximum mains current of 5,000 A AC.

Use appropriate insulation monitors when working in power installations, for example an insulation monitor measuring the pulse code.

We recommend refraining from using residual current devices (RCD). However, if an RCD is used within the mains, the residual current device must be of type B.

Power supply for the controls (electronics)

In case of external supply of the controls (electronics): The external power supply must have a reinforced insulation against the mains voltage in accordance with IEC 61800-5-1 and may only be supplied by a circuit limited to 150 VA in accordance with IEC 61800-5-1.

Potential of customer connections

All input signals (control) must be supplied with the same potential.

All output signals (status signals) must be supplied with the same potential.

Safety standards

All externally connected devices shall comply with the relevant safety standards.

All connected electric circuits shall comply with the requirements for protective separation.

Cable installation in accordance with EMC

Signal and bus cables are susceptible to interference.

Motor cables are interference sources.

- Lay cables being susceptible to interference or sources of interference at the highest possible distance from each other.
- The interference immunity of signal and bus cables increases if the cables are laid close to the earth potential.
- If possible, avoid laying long cables and make sure that they are installed in areas being subject to low interference.
- Avoid long parallel paths with cables being either susceptible to interference or interference sources.

Type of current, mains voltage and mains frequency

- For the connection of remote position transmitters, screened cables must be used.

Type of current, mains voltage and mains frequency must match the data on the motor name plate.

Figure 7: Name plate (example)

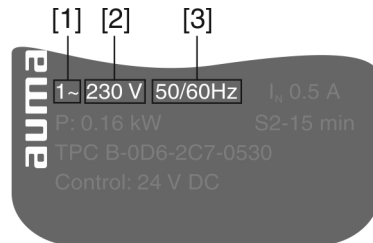

- [1] Type of current
- [2] Mains voltage
- [3] Mains frequency (for 1-ph AC motors)

Connecting cables

- For device insulation, appropriate (voltage-proof) cables must be used. Specify cables for the highest occurring rated voltage.
- Use connecting cable with appropriate minimum rated temperature.
- For connecting cables exposed to UV radiation (outdoor installation), use UV resistant cables.
- The cross-sectional area of every protective earthing conductor which does not form part of the supply cable or the cable enclosure, shall, in any case, not be less than:
 - With mechanical protection: minimum 2.5 mm²
 - Without mechanical protection: minimum 4 mm²

5.2. Connection via screw-type connector

Figure 8: Arrangement of connections

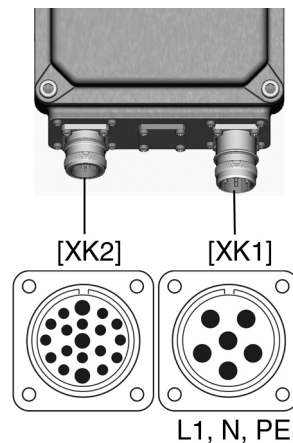

[XK1] Power terminals (mains cables)

[XK2] Control contacts

Cross sections:

- Power terminals: 1.0 – 1.5 mm² flexible
- Control contacts: 0.75 – 1.0 mm² flexible

**Hazardous voltage at open connector (capacitor discharge)!**

Risk of electric shock.

→ After disconnecting the power supply (removing connector for power terminals), wait at least 5 seconds before touching the pins/sockets.

For version with local controls on wall bracket (option):**NOTICE****Risk of damage to actuator electronics or DCS due to inadvertent exchanging of connectors!**

→ Do NOT connect 19-pin signal plug (from DCS) for control contacts [XK2] to socket for local controls on wall bracket.

5.2.1. Cable connection**Observe prior to connection**

- Observe permissible cross sections of connectors used.
- Use suitable crimping tools to connect wires:
 - For screw-type connectors:
e.g. Phoenix 4-arbor crimping pliers
 - For bayonet connectors:
e.g. Cannon four indent crimping tool
- Observe operation instructions of the connector manufacturer.
- Upon request, AUMA provide suitable connection sets.
- For further information refer to separate "Technical data Connector".
- Use in Ex zone 22 is only possible with straight single connectors and protective sleeves.

Figure 9: Fitting the protective sleeve (option)

**Steps**

1. Connect cables according to order-related wiring diagram.

WARNING**In case of a fault: Hazardous voltage while protective earth conductor is NOT connected!**

Risk of electric shock.

- Connect all protective earth conductors.
- Connect PE connection to external protective earth conductor of connecting cables.
- Start running the device only after having connected the protective earth conductor.

2. Connect protective earth conductor according to wiring diagram, symbol: ⊕.

5.3. Connection via bayonet connector

Figure 10: Arrangement of connections

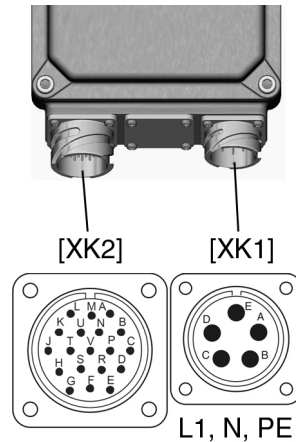

[XK1] Power terminals (mains cables)

[XK2] Control contacts

Cross sections:

- Power terminals: max. 1.5 mm² flexible
- Control contacts: max. 1.5 mm² flexible



Hazardous voltage at open connector (capacitor discharge)!

Risk of electric shock.

→ After disconnecting the power supply (removing connector for power terminals), wait at least 5 seconds before touching the pins/sockets.

5.3.1. Cable connection

Observe prior to connection

- Observe permissible cross sections of connectors used.
- Use suitable crimping tools to connect wires:
 - For screw-type connectors:
e.g. Phoenix 4-arbor crimping pliers
 - For bayonet connectors:
e.g. Cannon four indent crimping tool
- Observe operation instructions of the connector manufacturer.
- Upon request, AUMA provide suitable connection sets.
- For further information refer to separate "Technical data Connector".
- Use in Ex zone 22 is only possible with straight single connectors and protective sleeves.

Figure 11: Fitting the protective sleeve (option)

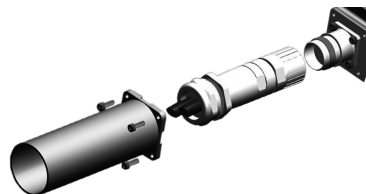

- Steps**
1. Connect cables according to order-related wiring diagram.



In case of a fault: Hazardous voltage while protective earth conductor is NOT connected!

Risk of electric shock.

- Connect all protective earth conductors.
- Connect PE connection to external protective earth conductor of connecting cables.
- Start running the device only after having connected the protective earth conductor.

2. Connect protective earth conductor according to wiring diagram, symbol: ⊕.

5.4. Connection with AUMA plug/socket connector

Figure 12: Connection with AUMA plug/socket connector

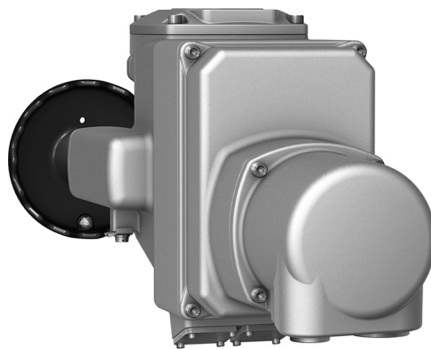

Cross sections AUMA plug/socket connector:

- Power terminals (U1, V1, W1, U2, V2, W2): max. 6 mm² flexible/10 mm² solid
- PE connection ⊕: max. 6 mm² flexible/10 mm² solid
- Control contacts (1 to 50): max. 2.5 mm²

5.4.1. Terminal compartment: open

Figure 13: Connection AUMA plug/socket connector, version S

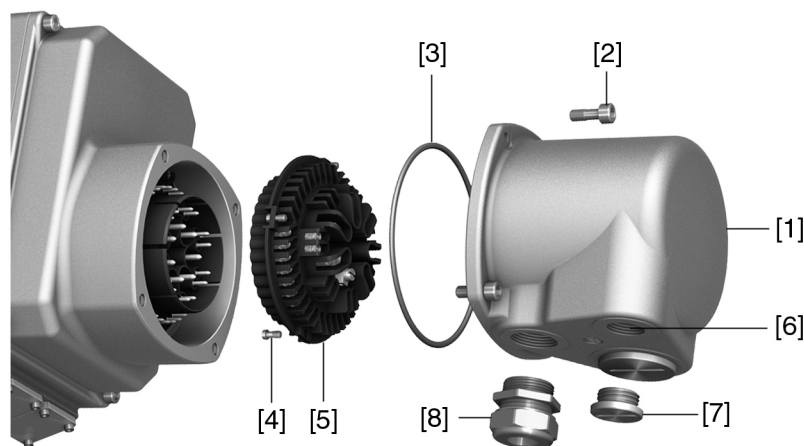

- [1] Cover
- [2] Screws for cover
- [3] O-ring
- [4] Screws for socket carrier
- [5] Socket carrier
- [6] Cable entry
- [7] Blanking plugs
- [8] Cable gland (not included in delivery)



Hazardous voltage!

Risk of electric shock.

→ Disconnect device from the mains before opening.

1. Loosen screws [2] and remove cover [1].
2. Loosen screws [4] and remove socket carrier [5] from cover [1].
3. Insert cable glands [8] suitable for connecting cables.
- ➔ The enclosure protection IP... stated on the name plate is only ensured if suitable cable glands are used.
4. Seal unused cable entries [6] with suitable blanking plugs [7].
5. Insert the cables into the cable glands [8].

5.4.2. Cable connection

✓ Observe permissible cross sections.

1. Remove cable sheathing.
2. Strip wires.
3. For flexible cables: Use end sleeves according to DIN 46228.
4. Connect cables according to order-related wiring diagram.



In case of a fault: Hazardous voltage while protective earth conductor is NOT connected!

Risk of electric shock.

→ Connect all protective earth conductors.

→ Connect PE connection to external protective earth conductor of connecting cables.

→ Start running the device only after having connected the protective earth conductor.

5. Tighten PE conductors firmly to PE connection using ring lugs (flexible cables) or loops (rigid cables).

Figure 14: PE connection

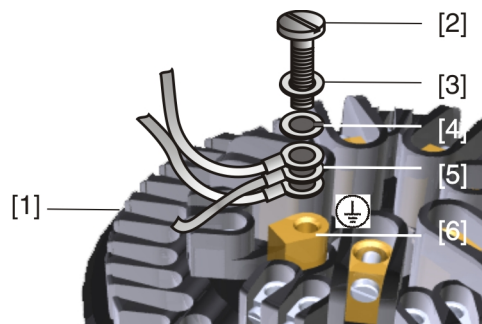

- | | |
|-----|---------------------------------------|
| [1] | Socket carrier |
| [2] | Screw |
| [3] | Washer |
| [4] | Lock washer |
| [5] | Protective earth with ring lugs/loops |
| [6] | PE connection, symbol: ⊕ |

5.4.3. Terminal compartment: close

Figure 15: Example: Version S

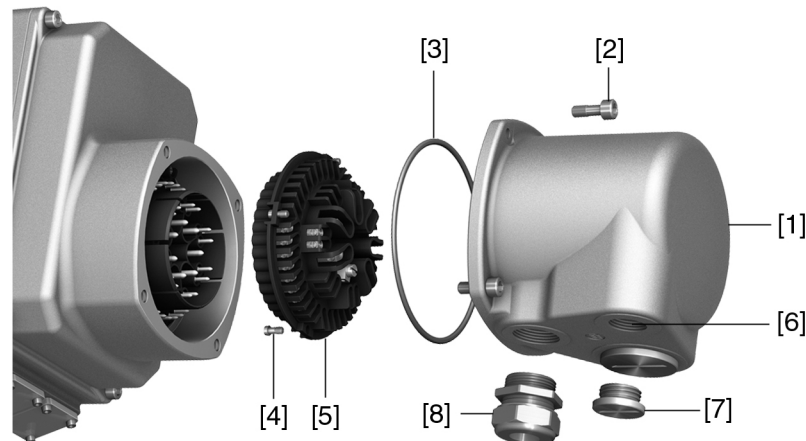

- [1] Cover
- [2] Screws for cover
- [3] O-ring
- [4] Screws for socket carrier
- [5] Socket carrier
- [6] Cable entry
- [7] Blanking plugs
- [8] Cable gland (not included in delivery)



Short-circuit due to pinching of cables!

Risk of electric shock and functional failures.

→ Carefully fit socket carrier to avoid pinching the cables.

1. Insert the socket carrier [5] into the cover [1] and fasten with screws [4].
2. Clean sealing faces of cover [1] and housing.
3. Check whether O-ring [3] is in good condition, replace if damaged.
4. Apply a thin film of non-acidic grease (e.g. petroleum jelly) to the O-ring and insert it correctly.
5. Fit cover [1] and fasten screws [2] evenly crosswise.
6. Fasten cable glands [8] applying the specified torque to ensure the required enclosure protection.

5.5. Earth connection, external

The housing is equipped with an external earth connection (U-bracket) to integrate the device in equipotential earth bonding.

Figure 16: Ground connection

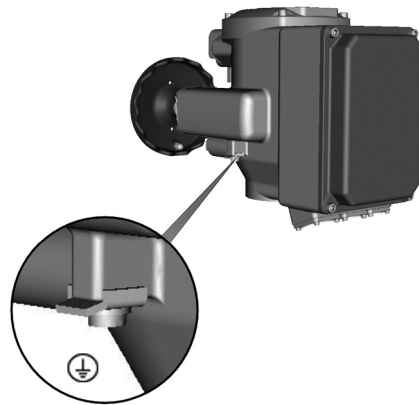

⊕ Earth connection (U-bracket), external

5.6. Accessories for electrical connection

5.6.1. Local controls mounted on wall bracket

— Option —

The wall bracket allows separate mounting of local controls and actuator.

Application If the actuator cannot be accessed safely.

Figure 17: Actuator with local controls on wall bracket

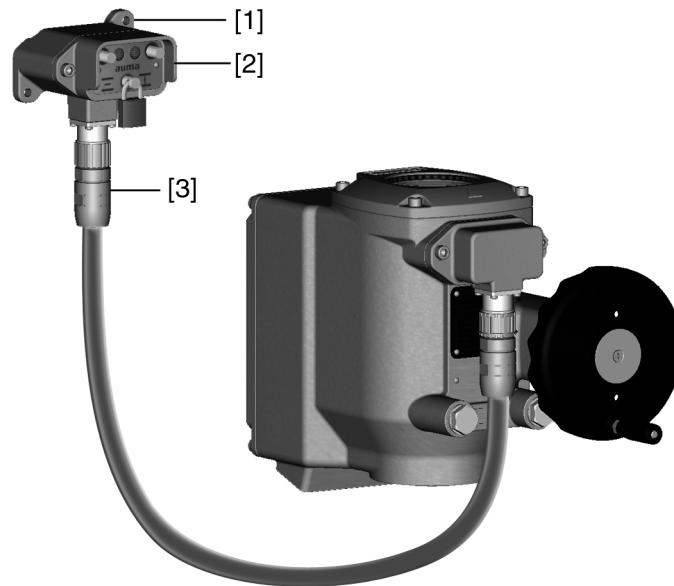

- [1] Wall bracket
- [2] Local controls
- [3] Phoenix connector with connecting cable

Observe prior to connection

- Permissible length of connecting cables: max. 30 m.
- We recommend: AUMA cable set K008.218 (5 m).
- A retrofit kit is available for actuators without wall bracket.
- Local controls on wall bracket are not approved for use in Ex zone 22.
- Establish cable connection via plug/socket connector as illustrated.

Information Do NOT connect 19-pin signal plug (from DCS) to socket for local controls on wall bracket.

6. Indications

6.1. Mechanical position indicator/running indication

Mechanical position indicator:

- Continuously indicates the valve position
- Indicates whether the actuator is running (running indication)
- Indicates that the end positions are reached (via indicator mark [3])

Figure 18: Mechanical position indicator

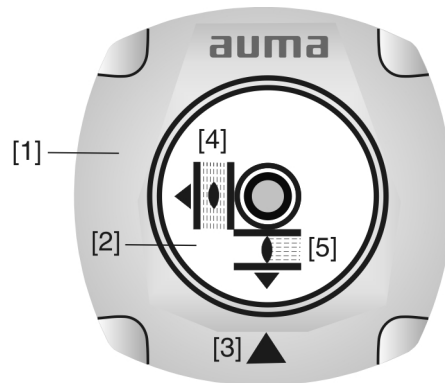

- [1] Cover
- [2] Indicator disc
- [3] Mark
- [4] Symbol for position OPEN
- [5] Symbol for position CLOSED

6.2. Indication lights

Figure 19: Indication lights on local controls



- [1] Indication light OPEN/warning/fault (green/yellow/red)
- [2] Indication light CLOSE/LOCAL/set end position (yellow/blue)

Table 4: Indication light [1] (default setting)

Colour/state	Signification	Description
illuminated in green	OPEN	Actuator is in end position OPEN.
blinking in yellow	Warning	Stroke between selected end positions (OPEN/CLOSED) is below the preset minimum stroke (factory setting 60 % of maximum rotation). Refer to <Corrective action> chapter.
blinking in red	Fault	The number of blinking signals indicates the number of fault signal. Refer to <Corrective action> chapter.

Table 5: Indication light [2] (default setting)

Colour/state	Signification	Description
illuminated in yellow	CLOSE	Actuator is in end position CLOSED.
blinking in blue (1 Hz)	LOCAL	Operation mode LOCAL is active. The actuator can be operated via push buttons.

Colour/state	Signification	Description
blinking in blue (5 Hz)	Set end position	Setting mode for end position setting is active.

7. Signals

7.1. Output contacts (binary)

The integral controls are equipped with 4 semiconductor output contacts.

Rated power: 24 V DC, 1A

Switches: 1 NO (standard)

Default values:

Designation of output contacts in wiring diagram	Designation of output contact in AUMA CDT software
K 1 = End position CLOSED	Signal DOUT 1 = End position CLOSED
K 2 = End position OPEN	Signal DOUT 2 = End position OPEN
K 3 = Fault	Signal DOUT 3 = Fault
K 4 = (Selector switch) REMOTE	Signal DOUT 4 = Selector sw. REMOTE

7.2. Analogue signals

— Option —

Valve position Signal: E2 = 0/4 – 20 mA (galvanically isolated)
 Designation in the wiring diagram:
 ANOUT1 (position)

8. Operation

8.1. Manual operation

For purposes of setting and commissioning, in case of motor failure or power failure, the actuator may be operated manually.

The handwheel does not rotate during motor operation. Change-over from motor operation to manual operation is not required.

1. Close valve: Turn crank handle/handwheel clockwise.



➔ Drive shaft (valve) turns clockwise in direction CLOSE.

2. Open valve: Turn crank handle/handwheel counterclockwise.



➔ Drive shaft (valve) turns counterclockwise in direction OPEN.

Information Turning the handwheel during motor operation extends or reduces the operating time, depending on the direction of rotation.

8.2. Motor operation

- ✓ Perform all commissioning settings and the test run prior to motor operation.

8.2.1. Local actuator operation

The actuator can be locally operated by means of push buttons.

Figure 20: Local controls

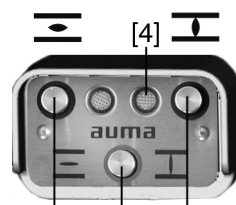

- [1] Push button OPEN
- [2] Push button STOP - operation mode LOCAL/REMOTE
- [3] Push button CLOSE
- [4] Indication light for operation mode LOCAL (blue)



Hot surfaces, e.g. possibly caused by high ambient temperatures or strong direct sunlight!

Danger of burns

→ Check surface temperature and wear protective gloves, if required.

Activate operation mode LOCAL:

→ Hold down push button [2] for approx. 3 seconds until the indication light [4] is blinking in blue.

➔ If the right indication light is blinking in blue, the actuator can be operated via push buttons [1 – 3]:

- Run actuator in direction OPEN: Press push button OPEN [1].
- Stop actuator: Press push button STOP [2].
- Run actuator in direction CLOSE: Press push button CLOSE [3].

Information OPEN - CLOSE operation commands can be given either in **push-to-run** or in **self-retaining** operation mode. In self-retaining mode, the actuator runs to the defined end position after pressing the button, unless another command has been received beforehand.

Push-to-run operation or self-retaining is set via the controls software. Refer to <AUMA CDT software (accessories)> chapter. It is possible to temporarily (for one operation command) activate self-retaining by means of the push buttons:

→ Press and hold down push buttons OPEN [1] or CLOSE [3] for more than 3 seconds.

During this procedure, self-retaining is not saved. The setting programmed within the software is taken over for the subsequent operation command.

8.2.2. Actuator operation from remote

Operation mode Remote can be activated via local controls.

Figure 21: Local controls



[2] Operation mode LOCAL/REMOTE

[4] Indication light for operation mode LOCAL (blue)

Activate operation mode Remote by means of local controls:

→ If indication light [4] is blinking in blue: Hold down push button [2] for approx. 3 seconds until the blue indication light goes out.

➔ Now, it is possible to operate the actuator via remote control, via operation commands (OPEN, STOP, CLOSE) or analogue setpoints (e.g. 0/4 – 20 mA).

Change-over between OPEN - CLOSE control and setpoint control:

For actuators equipped with a positioner, it is possible to select between **OPEN - CLOSE control** (REMOTE OPEN-CLOSE) and **setpoint control** (REMOTE SETPOINT).

- MODE input: + 24 V DC = REMOTE OPEN-CLOSE
Control is made via digital operation commands OPEN, STOP, CLOSE.
- MODE input: 0 V (or input open-circuit) = REMOTE SETPOINT
Control takes place via an analogue signal (e.g. 0/4 – 20 mA).

EMERGENCY operation:

- An EMERGENCY operation is initiated by a signal at the EMERGENCY input.
- The actuator moves to a predefined EMERGENCY position (i.e. end position OPEN or end position CLOSED).
- During EMERGENCY operation, the actuator does not react on other operation commands such as Fieldbus/OPEN/Fieldbus/CLOSE or Fieldbus SETPOINT.

9. Commissioning (basic settings of controls)

To prevent valve damage and disturbances during commissioning, the basic settings of controls must be verified prior to electrical actuator operation (motor operation) and adapted in compliance with the requirements of both valve and application.

Basic settings of controls comprise:

- Setting the type of seating
- Setting the torque switches
- Setting the output speed

To perform basic settings, proceed as follows:

1. via **switches** (directly at the device);
For switch setting, open controls cover.
2. via **AUMA CDT software** (accessories);
By connecting a PC, laptop or PDA.
Also refer to <AUMA CDT software (accessories)> chapter.

Please also refer to <AUMA CDT software (accessories)> chapter for further settings.

9.1. Cover to controls: open

The cover to the integral controls must be opened to perform the following settings (options).



Hazardous voltage!

Risk of electric shock.

→ Disconnect device from the mains before opening.

→ Loosen 4 screws and remove cover [1] to controls.

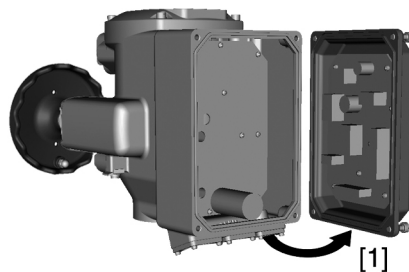

9.2. Setting via hardware (switches) or via software

The switch [S5] position determines whether the hardware settings (switches) or the software settings (via AUMA CDT software) are currently active.

Figure 22: Switch [S5] = Hardware/software mode

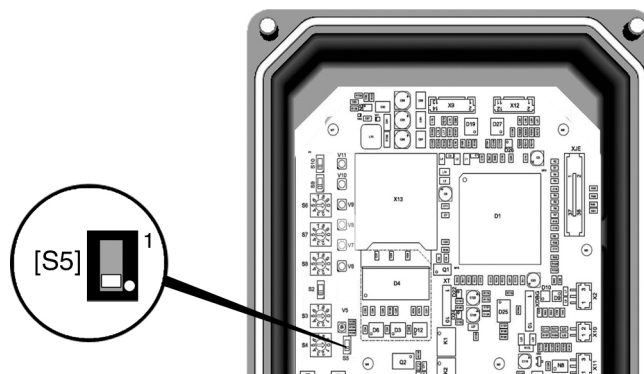



Table 6: Switch [S5] functions

OFF		Hardware mode (factory setting on delivery) Settings of switches [S2] through [S4] and [S6] through [S10] are valid. The values cannot be changed via AUMA CDT software.
ON		Software mode (sliding switch at white dot) Settings of switches [S2] through [S4] and [S6] through [S10] are NOT relevant. Settings are defined via software parameters.

9.3. Type of seating: set

NOTICE

Valve damage due to incorrect setting!

- The type of seating must suit the valve.
- Only change the setting with the consent of the valve manufacturer.

Setting via switches

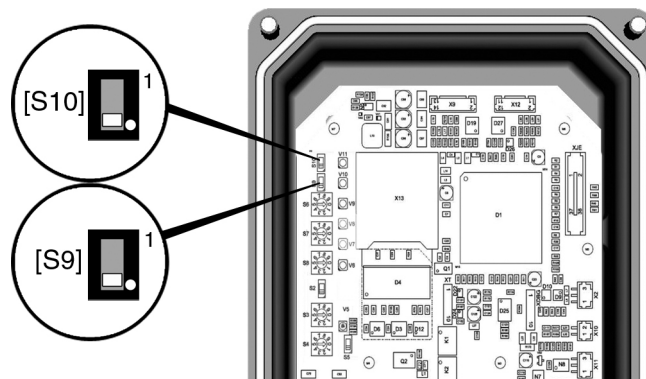

Condition: Switch [S5] in position OFF (hardware mode).

Figure 23: Switches for type of seating



- [S9] End position OPEN
- [S10] End position CLOSED

Table 7: Function of switches [S9], [S10]

ON		Limit seating, sliding switch at white dot
OFF		Torque seating

Setting via software parameters (AUMA CDT)

Condition: Switch [S5] is in position ON (software mode).

Setting parameters

- M ▷ Customer settings
 - Type of seating
 - End position CLOSED
 - End position OPEN

Default value: Limit

Setting values:

- Limit Limit seating in end positions.
- Torque Torque seating in end positions.

9.4. Torque switching: set

NOTICE

Valve damage due to excessive tripping torque limit setting!

- The tripping torque must suit the valve.
- Only change the setting with the consent of the valve manufacturer.

Once the set tripping torque is reached, the controls automatically switch off the actuator (overload protection of the valve).

Setting via switches

Condition: Switch [S5] is in position OFF (hardware mode).

Figure 24: Switches for tripping torque

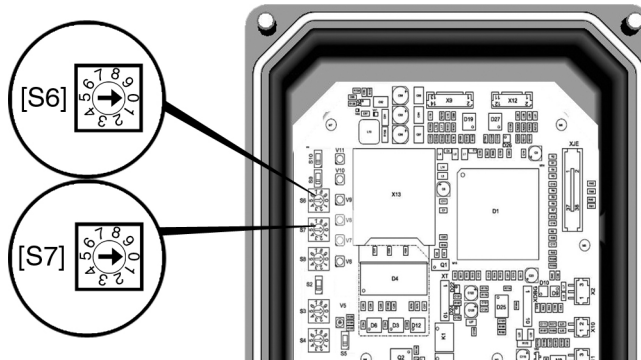

[S6] Tripping torque in direction OPEN

[S7] Tripping torque in direction CLOSE

Default value: depending on the order

Setting range: in 8 steps (refer to tables), linear from 40 – 100 % of the maximum tripping torque.

Table 8:

Switch steps	Tripping torques [Nm]		
	SVC/SVCR 05.1	SVC/SVCR 07.1	SVC/SVCR 07.5
0 - 1	10	20	40
2 - 3	>	>	>
4	15	30	60
5	>	>	>
6	20	40	80
7	>	>	>
8 - 9	25	50	100
> intermediate value			

Setting via software parameters (AUMA CDT)

Condition: Switch [S5] is in position ON (software mode).

Setting parameters

- M ▷ **Customer settings**
 - Torque switching
 - Tripping torque CLOSE (S7)
 - Tripping torque OPEN (S6)

Default value: depending on the order

Setting ranges: adjustable between 40 – 100 % of the maximum tripping torque

9.5. Output speed: set

Output speed at output drive is defined by the motor speed.

Setting via switches

Condition: Switch [S5] is in position OFF (hardware mode)

Figure 25: Speed switch

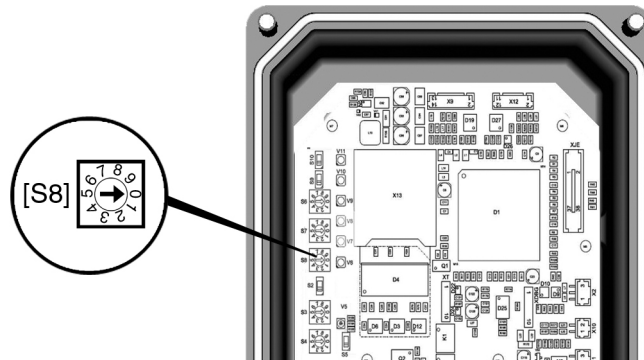

[S8] Output speed

Default value: depending on the order

Setting range: 9 steps (refer to table)

Table 9:

Switch [S8] Step	SVC/SVCR 05.1/07.1	SVC/SVCR 07.5
	Output drive speed [rpm]	
1	1.6	0.6
2	2.2	0.8
3	3.2	1.1
4	4	1.6
5	5.6	2.2
6	8	3.2
7	11	4
8	16	5.6
9	22	8
0	impermissible switch position	

Setting via software parameters (AUMA CDT)

The motor speed can be modified via the software parameters described hereafter: Contrary to output speed setting using switch [S8], setting via software parameters offers the following additional possibilities:

- different motor speeds for operation modes Local and Remote
- adjustable motor speed setting
- motor speed setting (target speed) for operation mode Remote by an external signal (0/4 – 20 mA) via analogue input AIN 1

Setting parameters

Condition: Switch [S5] is in position ON (software mode).

- M ▷ **Device configuration**
 - Motor speed
 - Speed LOCAL
 - Speed REMOTE
 - Speed I/O interface

Description of parameters:

Speed LOCAL Output speed for operation via local controls (operation mode Local); Setting range: linear between 0 – 100 % (0 % = min. motor speed, 100 % = max. motor speed); Default value = 50.0 %

Speed REMOTE Output speed in operation mode Remote for setting the **Speed I/O interface = Internal** parameter; Setting range: linear between 0 – 100 % (0 % = min. motor speed, 100 % = max. motor speed); Default value = 50.0 %

Speed I/O interface = **External**

In operation mode Remote, the output speed is defined via analogue input AIN (0/4 – 20 mA).

= **Internal**

In operation mode Remote, the output speed is not defined via analogue input AIN 1 but via the **Speed REMOTE** software parameter.

Table 10: Example values of type range settings SVC/SVCR 05.1/07.1

Output speed via parameter: Speed LOCAL Speed REMOTE	Output speed via AIN1 (Speed I/O interface = External)		Output speed Motor [rpm]	Output speed Output drive [rpm]
	0 – 20 mA	4 – 20 mA		
0.0 %	0.0	4.0	133	1.6
2.0 %	0.4	4.3	176	2.2
6.0 %	1.2	4.9	256	3.2
9.0 %	1.8	5.4	320	4
15.0 %	3.0	6.4	448	5.6
24.0 %	4.8	7.8	640	8
35.0 %	7.1	9.6	880	11
54.0 %	10.8	12.7	1280	16
77.0 %	15.4	16.3	1760	22
100.0 %	20.0	20.0	2250	28.1

Table 11: Example values of type range settings SVC/SVCR 07.5

Output speed via parameter: Speed LOCAL Speed REMOTE	Output speed via AIN1 (Speed I/O interface = External)		Output speed Motor [rpm]	Output speed Output drive [rpm]
	0 – 20 mA	4 – 20 mA		
0.0 %	0.0	4.0	133	0.6
2.0 %	0.5	4.4	186	0.8
6.0 %	1.2	4.9	255	1.1
11.0 %	2.3	5.8	371	1.6
18.0 %	3.6	6.9	510	2.2
29.0 %	5.8	8.6	742	3.2
38.0 %	7.5	10.0	928	4.0
55.0 %	11.0	12.8	1,299	5.6
81.0 %	16.3	17.0	1,856	8.0
100.0 %	20.0	20.0	2,250	9.7

9.6. Cover to controls: close

1. Clean sealing faces of housing and cover.
2. Apply a thin film of non-acidic grease (e.g. petroleum jelly) to the sealing faces.
3. Check whether seal is in good condition, replace seal if damaged.

4. Apply a thin film of non-acidic grease (e.g. petroleum jelly) to the seal and insert it correctly.

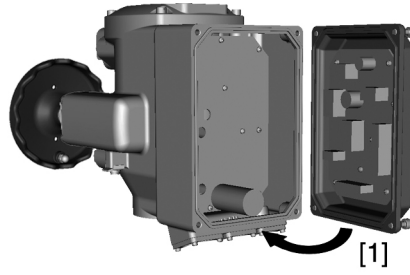

5. Place cover [1].
6. Fasten screws evenly crosswise.

10. Commissioning (basic settings at actuator)

10.1. End position detection: verify setting

1. Activate operation mode LOCAL:
 - If indication light [4] is blinking in blue: Operation mode LOCAL is already active.
 - Indication light [4] is NOT blinking in blue: → Hold down push button [2] for approx. 3 seconds until the indication light is blinking in blue.
- ↳ The actuator can be operated using the push buttons [1 – 3]:

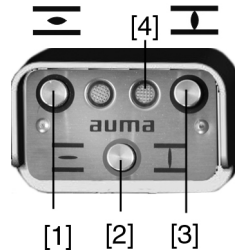

2. Operate actuator using push buttons OPEN, STOP, CLOSE.
 - ↳ The end position detection is set correctly if (default indication):
 - the right indication light [3] is illuminated in yellow in end position CLOSED
 - the left indication light [1] is illuminated in green in end position OPEN
 - the indication lights go out after travelling into opposite direction.
 - ↳ The end position detection is set incorrectly, if:
 - the actuator comes to a standstill before reaching the end position
 - the left indication light is blinking in red
3. If the end position setting is incorrect or not precise: <End position detection: set again via local controls>.

10.2. End position detection: set again via local controls

Operation mode LOCAL must be activated for end position setting.

Activate operation mode LOCAL:

- Hold down push button [2] for approx. 3 seconds until right indication light is blinking in blue.

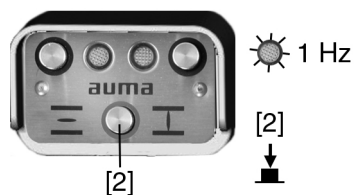

Information If the local controls are not provided on site, it is possible to connect an external control module. The setting is then performed in the same way as described below.

10.2.1. End position CLOSED: set again**Activate setting mode "end position setting":**

1. Press push button [2] – hold down and press push buttons [1] and [3] at the same time.

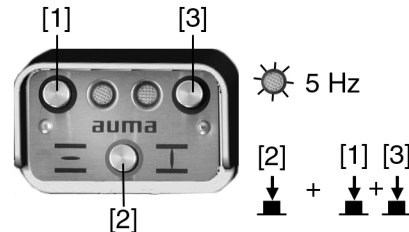

➔ Now, the right indication light is blinking faster (5 Hz).

Set end position CLOSED:

2. Use crank handle/handwheel or push button [3] for running the actuator to end position CLOSED. (Actuator runs at reduced output speed in setting mode.)

Information: If the red indication light is blinking (6 blinks), the actuator is outside the permissible setting range (0 – 100 %).



During electrical operation via push buttons, the actuator stops and cannot resume operation (up to valve end position). Since end position setting is not permissible while the indication light is blinking in red, potentiometer setting must be performed in a first step (also refer to <Potentiometer setting> chapter). Once this procedure is complete, setting can be resumed and the end position can be set again as described .

3. Press push button [2] – hold it down and press push button [3]. Hold both push buttons down until the right indication light is blinking alternately in yellow and blue (default).

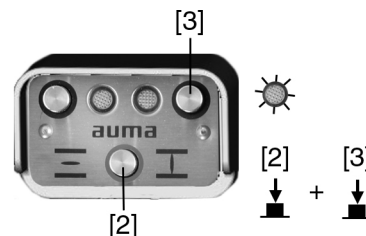

➔ If the right indication light is blinking in yellow/blue, end position CLOSED setting is complete.

10.2.2. End position OPEN: set again**Activate setting mode "end position setting":**

1. Press push button [2] – hold down and press push buttons [1] and [3] at the same time.

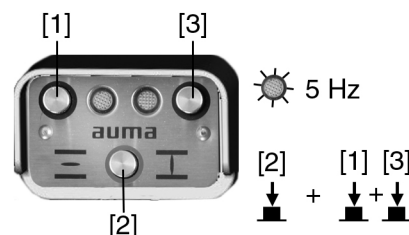

➔ Now, the right indication light is blinking faster (5 Hz).

Set end position OPEN:

2. Use crank handle/handwheel or push button [1] for running actuator to end position OPEN. (Actuator runs at reduced output speed in setting mode.)
Information: One of the reasons that end positions OPEN cannot be set (left indication light is blinking in red) could be that the stroke between both end positions (OPEN/CLOSED) is too large. In this instance, the primary reduction gearing must be replaced (by the AUMA service).
3. Press push button [2] – hold it down and press push button [1]. Hold both push buttons down until the left indication light is blinking in green (default).

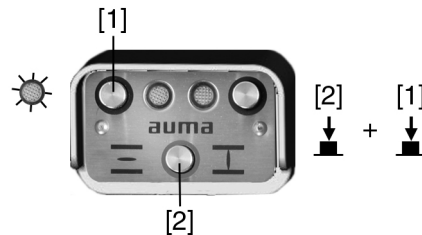

- ➔ Once the left indication light is illuminated in green (default), end position OPEN setting is complete.
- 4. Once both end positions are set, perform a reference operation, i.e. both end positions must be approached again – either via push buttons [1]/[3] (in operation mode Local) or from Remote (deactivate operation mode Local).

Deactivate operation mode Local:

5. Hold down push button [2] for approx. 3 seconds until blue indication light goes out.
- ➔ Now, the actuator can be controlled from Remote:
 - via operation commands (OPEN - STOP - CLOSE) in positions OPEN or CLOSED.
 - as an option via setpoint indication (e.g. 0/4 – 20 mA) in defined positions between 0 % and 100 % of setting range.

Information

- If the left indication light is blinking in yellow once the setting of both end positions is performed, the stroke between both end positions (OPEN/CLOSED) is too small.

10.3. Switch compartment: open

The switch compartment must be opened to perform the following settings (options).

- Loosen screws [2] and remove cover [1] from the switch compartment.

Figure 26:

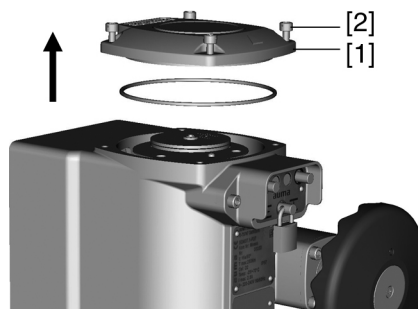
**10.4. Potentiometer setting**

The potentiometer is used as travel sensor and records the valve position.

Information The valve position (position at output drive) is transmitted to the potentiometer via a reduction gearing. The highest resolution and thus best positioning accuracy is achieved if the selected stroke between end positions OPEN and CLOSED is as close as possible to the maximum actuator stroke (max. turn range).

The actuators are available with different maximum turn ranges (= max. number of turns). The maximum actuator turn range is defined by the respective reduction gearing. Exchanging the reduction gearing and consequently changing the max. turn range can only be performed by the AUMA service.

The potentiometer is set in the factory. Turning the potentiometer by means of the setting screw [1] results in modification of the end position detection!

→ Only set potentiometer if the end position detection cannot be set: Fault signal "Actuator is outside the permissible position" or the indication light blinks in red 6 times.

If the stroke to be set is larger than the maximum actuator stroke, replace the reduction gearing selecting a unit with a higher maximum stroke value (max. turn range).

1. Remove retaining washer [4] and take off indicator disc [3].

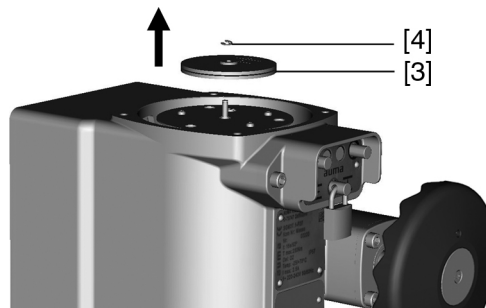

2. Move valve to end position CLOSED.
3. Turn potentiometer [1] counterclockwise until stop is felt.

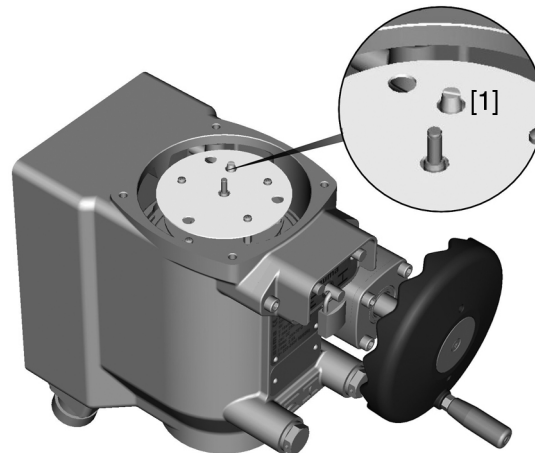

- ➔ End position CLOSED corresponds to 0 %
 - ➔ End position OPEN corresponds to 100 %
4. Turn potentiometer [1] slightly in opposite direction (for actuators with local controls: until the red indication light goes out).

- Place indicator disc [3] and secure with retaining washer [4].

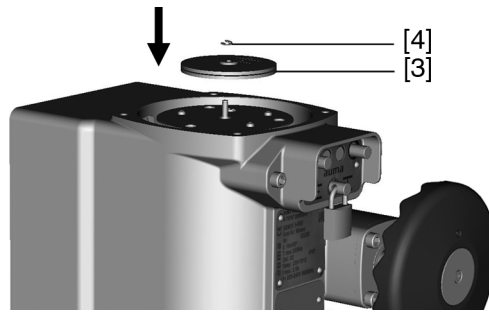

Information Once the potentiometer setting has been modified, repeat end position detection setting. Refer to <End position detection: set again via local controls> chapter.

10.5. Mechanical position indicator: set

- Move valve to end position CLOSED.
- Turn lower indicator disc until symbol  (CLOSED) is in alignment with the ▲ mark on the cover.



- Move actuator to end position OPEN.
- Hold lower indicator disc in position and turn upper disc with symbol  (OPEN) until it is in alignment with the ▲ mark on the cover.



- Move valve to end position CLOSED again.
- Check settings:
 - If the symbol  (CLOSED) is no longer in alignment with ▲ mark on the cover:
 - Repeat setting procedure.
 - Check potentiometer setting.

10.6. Switch compartment: close

- Clean sealing faces of housing and cover.
- Apply a thin film of non-acidic grease (e.g. petroleum jelly) to the sealing faces.
- Check whether O-ring [3] is in good condition, replace if damaged.

4. Apply a thin film of non-acidic grease (e.g. petroleum jelly) to the O-ring and insert it correctly.

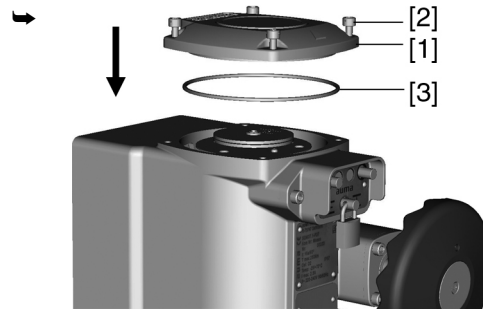

5. Place cover [1] on switch compartment.
6. Fasten screws [2] evenly crosswise.

11. AUMA CDT software (accessories)

The AUMA CDT software (accessories) can be used to establish a connection to a computer (PC, laptop or PDA).

It can be downloaded free of charge from our web site www.auma.com.

Figure 27: Connection with service cable

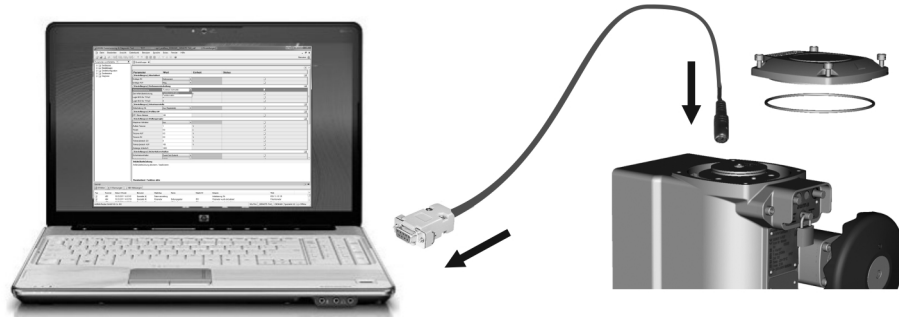

For connecting the computer to the integral actuator controls, a service cable (AUMA article no.: Z100.999) is required.

Read/perform basic settings via AUMA CDT

Basic settings at the device (in controls) made via switches are read only via AUMA CDT on delivery and cannot be modified. To be able to change these parameters via software, position switch [S5] in controls to "Software mode". Refer to <Settings via hardware (switches) or via software> chapter.

Switches and software parameters are set to the same values upon delivery (factory settings).

Further settings via AUMA CDT

Apart from basic settings, the following functions may additionally be set via AUMA CDT software:

- Torque by-pass
Allows suspending torque monitoring at actuator start-up. Duration for torque by-pass is adjustable.
- Electronic positioner (option)
- Failure behaviour (on loss of signal)
- EMERGENCY behaviour (option)
- Timer function (option)
- Motion detector
- Type of duty monitoring (motor starts and running time)
- Operating time monitoring
- Self-retaining local

For detailed information on these functions, refer to the online help of the AUMA CDT software.

12. Corrective action

12.1. Fault indications and warning indications

Faults interrupt or prevent the electrical actuator operation.

Faults and warnings can be signalled via the two output contacts and/or via the local controls.

Should local controls be available, the fault and warning signals are indicated by the left indication light [1].

Figure 28: Fault indications and RESET

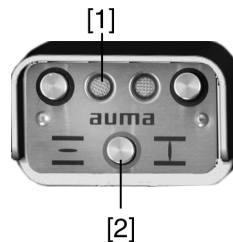

[1] Red indication light: Fault, yellow: Warning

[2] Push button RESET

In operation mode LOCAL (right indication light is blinking in blue), stored faults (cause does no longer exist), may be reset using the push button RESET [2] (hold it down for more than 1 second).

The tables below show the fault signalling via the indication lights of the local controls.

Table 12: Fault signalling via the red indication light

Indication	Signal	Signification (default)
1 blink	Fault indication 1	Torque fault → Press push buttons OPEN or CLOSE to reset the fault (indication light) by operating the device in the opposite direction.
2 blinks	Fault indication 2	Thermal fault (motor protection tripped) → Cool down, wait.
3 blinks	Fault indication 3	Signal loss of analogue input (4 – 20 mA)
4 blinks	Fault indication 4	Operation mode DISABLED: Operation via the local controls is disabled (Enable local controls function).
5 blinks	Fault indication 5	Fault E2 (actual value of positioner) → Check wiring (for possible loss of signal) of E2. → Read detailed fault indication via AUMA CDT software (accessories).
6 blinks	Fault indication 6	Actuator is outside the permissible position (potentiometer signal). → Set potentiometer again.
7 blinks	Fault indication 7	Fault of controls temperature
8 blinks	Fault indication 8	Collective signal: Internal error has occurred. → Read detailed fault indication via AUMA CDT software (accessories) and contact AUMA service.
9 blinks	Fault indication 9	Collective signal for all other faults

In case several faults have occurred, only the fault with the highest priority will be signalled. Fault indication 1 has the highest, fault indication 9 the lowest priority.

Table 13: Warning signalling via yellow indication light

Indication	Signal	Signification (default)
Blinking	Warning	For reasons of accuracy, we recommend selection of the stroke higher than 60 % of the maximum turn range. → Abort warning: Set again Low limit Uspan parameter via AJMA CDT software within the Position transmitter potentiometer sub-menu. → Remedy warning: Reduce maximum turn range by replacing the reduction gearing through the AJMA service.

12.2. Fuses

12.2.1. Fuses within the actuator controls

The primary fuse F1 is located on the power board (device protection fuse). It becomes visible when removing the cover to the controls. The fuse cannot be replaced. Only by replacing the entire power board can the fuse be exchanged.



Hazardous voltage!

Risk of electric shock.

→ Disconnect device from the mains before opening.

Figure 29: Primary fuse on power board

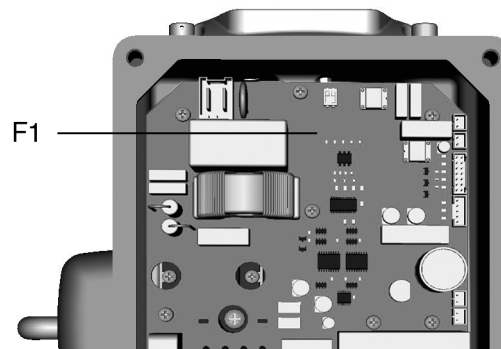

12.2.2. Motor protection (thermal monitoring)

In order to protect against overheating and impermissible high surface temperatures at the actuator, a PTC thermistor is embedded in the motor winding. Motor protection trips as soon as the max. permissible winding temperature has been reached.

The actuator is stopped and controls signals a fault. The left indication light of the local controls is blinking in red.

The motor has to cool down before operation can be resumed.

13. Servicing and maintenance



Damage caused by inappropriate maintenance!

- Servicing and maintenance must be carried out exclusively by suitably qualified personnel having been authorised by the end user or the contractor of the plant. Therefore, we recommend contacting our service.
- Only perform servicing and maintenance tasks when the device is switched off.

AUMA Service & Support

AUMA offer extensive service such as servicing and maintenance as well as customer product training. For the relevant contact addresses, please refer to <Addresses> in this document or to the Internet (www.auma.com).

13.1. Preventive measures for servicing and safe operation

The following measures are required to ensure safe device operation:

6 months after commissioning and then every year

- Check fastening screws between actuator and gearbox/valve for tightness. If required, fasten screws while applying the tightening torques as indicated in chapter <Assembly>.
- When rarely operated: Perform test run.

For enclosure protection IP68

After continuous immersion:

- Check actuator.
- In case of ingress of water, locate leaks and repair, dry device correctly and check for proper function.

13.2. Maintenance

Maintenance intervals

The maintenance intervals depend on load and application conditions having a major influence on the lubricating characteristics of the oil. Maintenance (incl. oil change/seal replacement) may only be carried out by the AUMA service.

Recommendations for maintenance:

- Generally after 4 to 6 years for modulating duty.
- Generally after 6 to 8 years if operated frequently (open-close duty).
- Generally after 10 to 12 years if operated rarely (open-close duty).

No additional lubrication of the gear housing is required during operation.

13.3. Disposal and recycling

Our devices have a long lifetime. However, they have to be replaced at one point in time. The devices have a modular design and may, therefore, easily be separated and sorted according to materials used, i.e.:

- electronic scrap
- various metals
- plastics
- greases and oils

The following generally applies:

- Greases and oils are hazardous to water and must not be released into the environment.
- Arrange for controlled waste disposal of the disassembled material or for separate recycling according to materials.
- Observe the national regulations for waste disposal.

14. Technical data Globe valve actuator

Type	Speed rpm	Torque range	Run torque ¹⁾ / Modulating torque ²⁾	Valve attach- ment	Valve shaft Max.			Handwheel		Weight ³⁾
					Cyl. [mm]	Square [mm]	Two- flat [mm]	Ø [mm]	Reduc- tion ra- tio	
SVC/ SVCR	(adjustable in 9 steps) 50 Hz/60 Hz	Max. [Nm]	Max. [Nm]	Standard EN ISO 5211						approx. [kg]
05.1	1.6 – 22	10 – 25	13	F05/F07	20	17	17	100	13:1	7.0
07.1	1.6 – 22	20 – 50	25	F07	25.4	22	22	125	13:1	10
07.5	0.6 – 8.0	40 – 100	50	F07	25.4	22	22	125	13:1	10

1) Permissible average torque for the whole travel or in modulating duty

2) Torque in modulating duty S4 - 40 %

3) Indicated weight includes globe valve actuator with controls, electrical connection in standard version, unbored coupling and handwheel

Features and functions of actuator		
Type of duty	Open-close duty SVC:	Short-time duty S2 - 15 min, classes A and B according to EN 15714-2
	Modulating duty SVCR:	Intermittent duty S4 - 40 %, class C according to EN 15714-2 with maximum number of starts of 1,800 cycles per hour
	For nominal voltage and 40 °C ambient temperature and at average running or modulating torque load The type of duty must not be exceeded.	
Motor	Variable speed, brushless motor	
Insulation class	F, tropicalized	
Motor protection	PTC thermistors (according to DIN 44081)	
Self-locking	Yes	
Limit switching (end position detection)	<ul style="list-style-type: none"> Via position transmitter potentiometer status signals for directions OPEN and CLOSE Turns per stroke: Subranges between 1– 99 (observe max. stem stroke) 	
Torque switching	Via electronic current measurement status signals for directions OPEN and CLOSE, adjustable in 8 steps	
Mechanical position indicator	Continuous indication, adjustable indicator disc with symbols OPEN and CLOSED	
Manual operation	Manual drive for setting and emergency operation, handwheel does not rotate during electrical operation	
Coupling	Standard:	Coupling unbored
	Options:	<ul style="list-style-type: none"> Coupling unbored extended Finish machining of coupling (standard or extended) <ul style="list-style-type: none"> Bore according to EN ISO 5211 with 1 keyway according to DIN 6885-1 Square bore according to EN ISO 5211 Two-flat according to EN ISO 5211
Valve attachment	Standard:	With coupling, dimensions according to EN ISO 5211
	Options:	<ul style="list-style-type: none"> With output drive type A With LE linear thrust unit With GS worm gearbox

Features and functions of actuator controls						
Power supply	Standard voltages:					
	1-phase AC current (voltages/frequencies)					
	<table border="1"> <tr> <td>Volt</td> <td>115</td> <td>230</td> </tr> <tr> <td>Hz</td> <td>50/60</td> <td>50/60</td> </tr> </table>	Volt	115	230	Hz	50/60
Volt	115	230				
Hz	50/60	50/60				
Permissible variation of mains voltage: $\pm 10\%$ Permissible variation of mains frequency: $\pm 5\%$ For current consumption, current type, mains voltage and frequency, refer to the name plate						
External supply of the electronics (option)	24 V DC $+20\%$ / -15% Current consumption: With options up to 200 mA The external power supply must have a reinforced insulation against mains voltage in accordance with IEC 61800-5-1 and may only be supplied by a circuit limited to 150 VA in accordance with IEC 61800-5-1.					
Overvoltage category	Category III according to IEC 60364-4-443					
Power electronics	Power electronics with integral motor controller					
Rated power	The controls are designed for the rated motor power, refer to name plate					
Control (input signals)	<ul style="list-style-type: none"> 4 digital inputs (via opto-isolator, with one common) <ul style="list-style-type: none"> Control voltage 24 V DC, current consumption: approx. 15 mA per input Minimum pulse duration for shortest operation pulse: 100 ms. All digital inputs must be supplied with the same potential. Assignment for open-close actuators: <ul style="list-style-type: none"> OPEN, STOP, CLOSE (standard) OPEN, STOP, CLOSE, EMERGENCY (option) OPEN, STOP, CLOSE, MODE in combination with positioner (option) OPEN, EMERGENCY, CLOSE, MODE in combination with positioner (option) Assignment for modulating actuators: <ul style="list-style-type: none"> OPEN, STOP, CLOSE, MODE (standard) OPEN, EMERGENCY, CLOSE, MODE Analogue input 0/4 – 20 mA (galvanically isolated) Used as input signal for position setpoint E1 (in combination with positioner) or as input signal for motor speed E3. 					
Status signals (output signals)	<ul style="list-style-type: none"> Output contacts: <ul style="list-style-type: none"> 4 programmable semi-conductor output contacts, per contact max. 24 V DC, 1 A (resistive load) <ul style="list-style-type: none"> 2 NO contacts with one common Default configuration: End position OPEN, end position CLOSED 1 potential-free NO contact for collective fault signal Default configuration: Torque fault, motor protection tripped 1 potential-free change-over contact Default configuration: Push button REMOTE Analogue output: <ul style="list-style-type: none"> Galvanically isolated position feedback 0/4 – 20 mA (load max. 500 Ω). 					
Voltage output	Auxiliary voltage 24 V DC, max. 40 mA for supply of control inputs, galvanically isolated from internal voltage supply Not available for option "external electronics supply".					
Local controls	Standard:	<ul style="list-style-type: none"> Push buttons OPEN, STOP (LOCAL - REMOTE), CLOSE 2 multi-colour programmable indication lights: <ul style="list-style-type: none"> End position CLOSED (yellow), fault/failure (red), end position OPEN (green), operation mode LOCAL (blue) 				
	Option:	Local controls mounted separately on wall bracket				

Features and functions of actuator controls	
Functions	<ul style="list-style-type: none"> • Switch-off mode adjustable: <ul style="list-style-type: none"> - Limit or torque seating for end position OPEN and end position CLOSED • Torque monitoring across the whole travel • Torque by-pass • Programmable EMERGENCY behaviour <ul style="list-style-type: none"> - Digital input low active - Reaction can be selected: Stop, run to end position CLOSED, run to end position OPEN • Positioner (for modulating actuators): <ul style="list-style-type: none"> - Position setpoint via analogue input E1 = 0/4 – 20 mA - Programmable behaviour on loss of signal - Automatic adaptation of the dead band (adaptive behaviour selectable) - Switch-over between OPEN - CLOSE control (REMOTE OPEN-CLOSE) and setpoint control (REMOTE SETPOINT) via digital MODE input
Electrical connection	Standard: Plug/socket connector with crimp connection
	Option: AUMA plug/socket connector with screw-type connection
Wiring diagram	Refer to name plate

Service conditions	
Mounting position	Any position
Installation altitude	≤ 2 000 m above sea level > 2,000 m above sea level on request
Ambient temperature	Refer to name plate Standard: –25 °C to +70 °C
Humidity	Up to 100 % relative humidity across the entire permissible temperature range
Enclosure protection according to EN 60529	Refer to name plate IP68 According to AUMA definition, enclosure protection IP68 meets the following requirements: <ul style="list-style-type: none"> • Depth of water: maximum 8 m head of water • Duration of continuous immersion in water: Max. 96 hours • Up to 10 operations during continuous immersion • Modulating duty is not possible during continuous immersion
Pollution degree	Pollution degree 4 (when closed) according to IEC 61800-5-1
Vibration resistance according to IEC 60068-2-6	2 g, from 10 to 200 Hz Resistant to vibration during start-up or for failures of the plant. However, a fatigue strength may not be derived from this.
GL approval	Environmental categories D, G, EMC2
Corrosion protection	Standard: KS: Suitable for use in areas with high salinity, almost permanent condensation, and high pollution.
	Option: KX: Suitable for use in areas with extremely high salinity, permanent condensation, and high pollution.
Finish coating	Standard: Two-component iron-mica combination
Colour	Standard: AUMA silver-grey (similar to RAL 7037)
	Option: Available colours on request
Lifetime	Open-close duty: 20,000 operating cycles OPEN - CLOSE - OPEN An operating cycle is based on an operation from CLOSED to OPEN and back to CLOSED
	Modulating duty: 5 million modulating steps The lifetime depends on the load and the number of starts. A high starting frequency will rarely improve the modulating accuracy. To reach the longest possible maintenance and fault-free operating time, the number of starts per hour chosen should be as low as permissible for the process.

Further information	
EU Directives	Electromagnetic Compatibility (EMC): (2004/108/EC) Low Voltage Directive: (2006/95/EC) Machinery Directive: (2006/42/EC)

Spare parts

Information: Please state device type and our order number (see name plate) when ordering spare parts. Only original AUMA spare parts should be used. Failure to use original spare parts voids the warranty and exempts AUMA from any liability. Delivered spare parts may slightly vary from the representation in these instructions.

Ref. no.	Designation	Type
002.0-1	Local controls	Sub-assembly
002.0-2	Cover (for version without local controls)	Sub-assembly
002.0-3	Cover with socket for separately mounted local controls	Sub-assembly
002.3-1	Board for local controls 002.0-1	Sub-assembly
002.3-2	Board in connecting cover 002.0-3	Sub-assembly
006.0	Power supply unit/switchgear	Sub-assembly
009.0	Logic board	
058.0	Wire for protective earth	Sub-assembly
500.0	Cover	Sub-assembly
501.0	Socket carrier (complete with sockets)	Sub-assembly
502.0	Pin carrier without pins	Sub-assembly
503.0	Socket for control	Sub-assembly
504.0	Socket for motor	Sub-assembly
505.0	Pin for controls	Sub-assembly
506.0	Pin for motor	Sub-assembly
507.0	Cover for electrical connection	Sub-assembly
525.0	Coupling	Sub-assembly
544.0	Screw plug	
541.0	Protective earth connection	Sub-assembly
542.1	Handwheel	Sub-assembly
542.2	Ball handle	Sub-assembly
545.0-1	Protective cap with cord	Sub-assembly
545.0-2	Protective cap without cord	Sub-assembly
545.0-3	Mating plug	Sub-assembly
587.0	Wall bracket	
611.0	Cover	Sub-assembly
S1	Seal kit, small	Set

16. Certificates

16.1. Declaration of Incorporation and EC Declaration of Conformity

AUMA Riester GmbH & Co. KG
 Aumastr. 1
 79379 Müllheim, Germany
 www.auma.com

Tel +49 7631 809-0
 Fax +49 7631 809-1250
 Riester@auma.com



Original Declaration of Incorporation of Partly Completed Machinery (EC Directive 2006/42/EC) and EC Declaration of Conformity in compliance with the Directives on EMC, Low Voltage and Explosion Protection

for electric AUMA globe valve actuators of type ranges **SVC 05.1 – SVC 07.5** and **SVCR 05.1 – SVCR 07.5** with **integral actuator controls**.

AUMA Riester GmbH & Co. KG as manufacturer declares herewith, that the above mentioned globe valve actuators meet the following basic requirements of the EC Machinery Directive 2006/42/EC: Annex I, articles 1.1.2, 1.1.3, 1.1.5, 1.2.1; 1.2.6, 1.3.1, 1.3.7, 1.5.1, 1.6.3, 1.7.1, 1.7.3, 1.7.4

The following harmonised standards within the meaning of the Machinery Directive have been applied:

EN 12100-1: 2003	ISO 5211: 2001
EN 12100-2: 2003	EN 60204-1: 2006

With regard to the partly completed machinery, the manufacturer commits to submitting the documents to the competent national authority via electronic transmission upon request. The relevant technical documentation pertaining to the machinery described in Annex VII, part B has been prepared.

AUMA globe valve actuators are designed to be installed on industrial valves. AUMA globe valve actuators must not be put service until the final machinery into which they are to be incorporated has been declared in conformity with the provisions of the EC Directive 2006/42/EC.

Authorised person for documentation: Peter Malus, Aumastrasse 1, D-79379 Müllheim

As partly completed machinery, the globe valve actuators further comply with the requirements of the following directives and the respective approximation of national laws as well as the respective harmonised standards as listed below:

(1) Equipment and protective systems intended for use in potentially explosive atmospheres (94/9/EC)

EN 60079-0: 2009	EN 13463-5: 2003
EN 61241-1: 2004	EN 1127-1: 2007
EN 13463-1: 2009	EN 60529: 2000

(2) Directive relating to Electromagnetic Compatibility (EMC) (2004/108/EC)

EN 61800-3: 2004

(3) Low Voltage Directive (2006/95/EC)

EN 61800-5-1: 2007

Year of affixing of the CE marking: 2010

The above mentioned globe valve actuators are available as an option in a special version for applications in Zone 22 category II3D and are marked with the designation II3D IP6X T150°C.

These globe valve actuators are available in enclosure protection IP 65, IP 67 or IP 68 and fulfil the requirements of EN 61241-1:2004 – Electrical apparatus for use in presence of combustible dust. To fulfil all requirements in compliance with EN 61241-1 – Electrical apparatus for use in presence of combustible dust according to procedure A, the indications contained in the operation instructions must imperatively be observed.

Müllheim, 2011-03-01

H. Newerla, General Management

This declaration does not contain any guarantees. The safety instructions in product documentation supplied with the devices must be observed. Non-concerted modification of the devices voids this declaration. Y005.090/002/en

Index**A**

Accessories (electrical connection)	21
Actuator: mount to valve	11
Ambient temperature	7 , 46
Analogue signals	24
Applications	4
Assembly	11
AUMA CDT (accessories)	8 , 40

B

Basic setting	34 , 40
Basic settings for controls	28

C

CDT (accessories)	8 , 40
Certificates	49
Change-over between OPEN - CLOSE control and setpoint control	26
Colour	46
Commissioning	4
Commissioning (basic settings)	34
Commissioning (controls)	28
Control	8
Corrective action	41
Corrosion protection	10 , 46
Coupling	44
Cross sections	18
Current consumption	14

D

Data Matrix code	8
Declaration of Incorporation	49
Device type	8
Directives	4
Disposal	43

E

EC Declaration of Conformity	49
Electrical connection	14
Electric power (motor)	7
EMC	14
EMERGENCY behaviour	40
EMERGENCY operation	27
Enclosure protection	7 , 46
End position detection setting	34
End position detection verification	34
End position detection	44

F

Failure behaviour	40
Fault indications	41
Finish coating	46
Flange size	8
Fuses	42

G

GL approval	46
Ground connection	20

H

Handwheel	11
Humidity	46

I

Identification	7
Indication lights	22
Indications	22
Indicator disc	22 , 38
Inspection record	8
Installation altitude	46
Insulation class	44

L

LEDs (indication lights)	22
Lifetime	46
Limit switching	44
Local controls	21 , 25
Loss of signal	40
Lubrication	43

M

Mains frequency	7 , 15
Mains voltage	7 , 15
Maintenance	4 , 43 , 43
Maintenance intervals	43
Manual operation	25 , 44
Mechanical position indicator	22 , 38 , 44
Modulating duty (REMOTE SETPOINT)	26
Monitoring	40
Motion detector	40
Motor	44
Motor operation	25
Motor power	7
Motor protection	44
Mounting position	46

N

Name plate	7 , 15
Network types	14

O

OPEN - CLOSE control (Remote OPEN - CLOSE)	26
Open-close duty (REMOTE OPEN-CLOSE)	26
Operating time monitoring	40
Operation	4 , 25
Order number	7 , 7 , 8
Output speed	7
Output speed setting	31

P		T	
Packaging	10	Terminal cross sections	15 , 17
Paint	46	Terminal plan	14
Pollution degree	46	Torque by-pass	40
Positioner	40	Torque range	7
Position indicator	38	Torque switching	30 , 44
Position transmitter	36	Transport	10
Potentiometer	36	Turns per stroke	7
Power (motor)	7	Type (device type)	8
Power supply	14 , 15	Type designation	7
Programming mode	40	Type of current	7 , 15
Protection on site	14	Type of duty	7 , 44
Protective measures	4	Type of lubricant	7
Push-to-run operation local	26 , 40	Type of seating	29
Q		V	
Qualification of staff	4	Valve attachment	44
R		Vibration resistance	46
Range of application	4	W	
Rated current	7	Wall bracket	21
Recycling	43	Wiring diagram	8 , 14
Remote actuator operation	26	Wiring diagram number	7
Running indication	22	Works number	8
S		Y	
Safety instructions	4	Year of manufacture	8
Safety instructions/warnings	4	Year of production	8
Self-locking	44		
Self-retaining local	26 , 40		
Serial number	7 , 8		
Service	43		
Servicing	43		
Setpoint control (Remote SETPOINT)	26		
Settings for controls	28		
Short-circuit protection	14		
Signals	24		
Signals (analogue)	24		
Size	8		
Software	28 , 40		
Spare parts	47		
Standards	4		
Storage	10		
Supply networks	14		
Support	43		
Support App	8 , 8		
Switch [S5] = MODE	40		

Europe

AUMA Riester GmbH & Co. KG

Plant Müllheim
DE 79373 Müllheim
 Tel +49 7631 809 - 0
 riester@auma.com
 www.auma.com

Plant Ostfildern-Nellingen
DE 73747 Ostfildern
 Tel +49 711 34803 - 0
 riester@wof.auma.com

Service-Center Bayern
DE 85386 Eching
 Tel +49 81 65 9017- 0
 Riester@scb.auma.com

Service-Center Köln
DE 50858 Köln
 Tel +49 2234 2037 - 900
 Service@sck.auma.com

Service-Center Magdeburg
DE 39167 Niederrandleben
 Tel +49 39204 759 - 0
 Service@scm.auma.com

AUMA-Armaturentriebe Ges.m.b.H.
AT 2512 Tribuswinkel
 Tel +43 2252 82540
 office@auma.at
 www.auma.at

AUMA BENELUX B.V. B. A.
BE 8800 Roeselare
 Tel +32 51 24 24 80
 office@auma.be
 www.auma.nl

ProStream Group Ltd.
BG 1632 Sofia
 Tel +359 2 9179-337
 valtchev@prostream.bg
 www.prostream.bg

OOO "Dunkan-Privod"
BY 220004 Minsk
 Tel +375 29 6945574
 belarus@auma.ru
 www.zatvor.by

AUMA (Schweiz) AG
CH 8965 Berikon
 Tel +41 566 400945
 RettichP.ch@auma.com

AUMA Servopohony spol. s.r.o.
CZ 250 01 Brandýs n.L.-St.Boleslav
 Tel +420 326 396 993
 auma-s@auma.cz
 www.auma.cz

GRØNBECH & SØNNER A/S
DK 2450 København SV
 Tel +45 33 26 63 00
 GS@g-s.dk
 www.g-s.dk

IBEROPLAN S.A.
ES 28027 Madrid
 Tel +34 91 3717130
 iberoplan@iberoplan.com

AUMA Finland Oy
FI 02230 Espoo
 Tel +358 9 5840 22
 auma@auma.fi
 www.auma.fi

AUMA France S.A.R.L.
FR 95157 Taverny Cedex
 Tel +33 1 39327272
 info@auma.fr
 www.auma.fr

AUMA ACTUATORS Ltd.
GB Clevedon, North Somerset BS21 6TH
 Tel +44 1275 871141
 mail@auma.co.uk
 www.auma.co.uk

D. G. Bellos & Co. O.E.
GR 13673 Acharnai, Athens
 Tel +30 210 2409485
 info@dgbellos.gr

APIS CENTAR d. o. o.
HR 10437 Bestovje
 Tel +385 1 6531 485
 auma@apis-centar.com
 www.apis-centar.com

Fabo Kereskedelmi és Szolgáltató Kft.
HU 8800 Nagykanizsa
 Tel +36 93/324-666
 auma@fabo.hu
 www.fabo.hu

Falkinn HF
IS 108 Reykjavik
 Tel +00354 540 7000
 os@falkinn.is
 www.falkinn.is

AUMA ITALIANA S.r.l. a socio unico
IT 20023 Cerro Maggiore (MI)
 Tel +39 0331 51351
 info@auma.it
 www.auma.it

AUMA BENELUX B.V.
LU Leiden (NL)
 Tel +31 71 581 40 40
 office@auma.nl

NB Engineering Services
MT ZBR 08 Zabbar
 Tel + 356 2169 2647
 nikibel@onvol.net

AUMA BENELUX B.V.
NL 2314 XT Leiden
 Tel +31 71 581 40 40
 office@auma.nl
 www.auma.nl

SIGUM A. S.
NO 1338 Sandvika
 Tel +47 67572600
 post@sigum.no

AUMA Polska Sp. z o.o.
PL 41-219 Sosnowiec
 Tel +48 32 783 52 00
 biuro@auma.com.pl
 www.auma.com.pl

AUMA-LUSA Representative Office, Lda.
PT 2730-033 Barcarena
 Tel +351 211 307 100
 geral@aumalusa.pt

SAUTECH
RO 011783 Bucuresti
 Tel +40 372 303982
 office@sautech.ro

OOO PRIWODY AUMA
RU 141402 Khimki, Moscow region
 Tel +7 495 221 64 28
 aumarussia@auma.ru
 www.auma.ru

OOO PRIWODY AUMA
RU 125362 Moscow
 Tel +7 495 787 78 21
 aumarussia@auma.ru
 www.auma.ru

ERICHs ARMATUR AB
SE 20039 Malmö
 Tel +46 40 311550
 info@erichsarmatur.se
 www.erichsarmatur.se

ELSO-b, s.r.o.
SK 94901 Nitra
 Tel +421 905/336-926
 elsob@stonline.sk
 www.elsob.sk

Auma Endüstri Kontrol Sistemleri Limited
 Sirketi
TR 06810 Ankara
 Tel +90 312 217 32 88
 info@auma.com.tr

AUMA Technology Automations Ltd
UA 02099 Kiev
 Tel +38 044 586-53-03
 auma-tech@aumatech.com.ua

Africa

Solution Technique Contrôle Commande
DZ Bir Mourad Rais, Algiers
 Tel +213 21 56 42 09/18
 stcco@wissal.dz

A.T.E.C.
EG Cairo
 Tel +20 2 23599680 - 23590861
 contactus@atec-eg.com

SAMIREG
MA 203000 Casablanca
 Tel +212 5 22 40 09 65
 samireg@menara.ma

MANZ INCORPORATED LTD.
NG Port Harcourt
 Tel +234-84-462741
 mail@manzincorporated.com
 www.manzincorporated.com

AUMA South Africa (Pty) Ltd.
ZA 1560 Springs
 Tel +27 11 3632880
 aumasa@mweb.co.za

America

AUMA Argentina Rep.Office
AR Buenos Aires
 Tel +54 11 4737 9026
 contacto@aumaargentina.com.ar

AUMA Automação do Brazil Ltda.
BR Sao Paulo
 Tel +55 11 4612-3477
 contato@auma-br.com

TROY-ONTOR Inc.
CA L4N 8X1 Barrie, Ontario
 Tel +1 705 721-8246
 troy-ontor@troy-ontor.ca

AUMA Chile Representative Office
CL 9500414 Buin
 Tel +56 2 821 4108
 aumachile@auma-chile.cl

Ferrostaal de Colombia Ltda.
CO Bogotá D.C.
 Tel +57 1 401 1300
 dorian.hernandez@ferrostaal.com
 www.ferrostaal.com

Transcontinental Trading Overseas SA.
CU Ciudad Habana
 Tel +53 7 208 9603 / 208 7729
 tto@ttoweb.com

AUMA Región Andina & Centroamérica
EC Quito
 Tel +593 2 245 4614
 auma@auma-ac.com
 www.auma.com

Corsusa International S.A.C.
PE Miraflores - Lima
 Tel +511444-1200 / 0044 / 2321
 corsusa@corsusa.com
 www.corsusa.com

Control Technologies Limited
TT Marabella, Trinidad, W.I.
 Tel + 1 868 658 1744/5011
 www.ctltech.com

AUMA ACTUATORS INC.
US PA 15317 Canonsburg
 Tel +1 724-743-AUMA (2862)
 mailbox@auma-usa.com
 www.auma-usa.com

Suplibarca
VE Maracaibo, Estado, Zulia
 Tel +58 261 7 555 667
 suplibarca@intercable.net.ve

Asia

AUMA Actuators UAE Support Office
AE 287 Abu Dhabi
 Tel +971 26338688
 Nagaraj.Shetty@auma.com

AUMA Actuators Middle East
BH 152 68 Salmabad
 Tel +97 3 17896585
 salesme@auma.com

Mikuni (B) Sdn. Bhd.
BN KA1189 Kuala Belait
 Tel + 673 3331269 / 3331272
 mikuni@brunet.bn

AUMA Actuators (China) Co., Ltd
CN 215499 Taicang
 Tel +86 512 3302 6900
 mailbox@auma-china.com
 www.auma-china.com

PERFECT CONTROLS Ltd.
HK Tsuen Wan, Kowloon
 Tel +852 2493 7726
 joeip@perfectcontrols.com.hk

PT. Carakamas Inti Alam
ID 11460 Jakarta
 Tel +62 215607952-55
 auma-jkt@indo.net.id

AUMA INDIA PRIVATE LIMITED.
IN 560 058 Bangalore
 Tel +91 80 2839 4656
 info@auma.co.in
 www.auma.co.in

ITG - Iranians Torque Generator
IR 13998-34411 Teheran
 +982144545654
 info@itg-co.ir

Trans-Jordan Electro Mechanical Supplies
JO 11133 Amman
 Tel +962 - 6 - 5332020
 Info@transjordan.net

AUMA JAPAN Co., Ltd.
JP 211-0016 Kawasaki-shi, Kanagawa
 Tel +81-(0)44-863-8371
 mailbox@auma.co.jp
 www.auma.co.jp

DW Controls Co., Ltd.
KR 153-702 Gasan-dong, GeumChun-Gu,, Seoul
 Tel +82 2 2624 3400
 import@actuatorbank.com
 www.actuatorbank.com

Al-Arfaj Engineering Co WLL
KW 22004 Salmiyah
 Tel +965-24817448
 info@arfajengg.com
 www.arfajengg.com

TOO "Armaturny Center"
KZ 060005 Atyrau
 Tel +7 7122 454 602
 armacentre@bk.ru

Network Engineering
LB 4501 7401 JBEIL, Beirut
 Tel +961 9 944080
 nabil.ibrahim@networkenglb.com
 www.networkenglb.com

AUMA Malaysia Office
MY 70300 Seremban, Negeri Sembilan
 Tel +606 633 1988
 sales@auma.com.my

Mustafa Sultan Science & Industry Co LLC
OM Ruwi
 Tel +968 24 636036
 r-negi@mustafasultan.com

FLOWTORK TECHNOLOGIES CORPORATION
PH 1550 Mandaluyong City
 Tel +63 2 532 4058
 flowtork@pltdsl.net

M & C Group of Companies
PK 54000 Cavalry Ground, Lahore Cantt
 Tel +92 42 3665 0542, +92 42 3668 0118
 sales@mcss.com.pk
 www.mcss.com.pk

Petrogulf W.L.L.
QA Doha
 Tel +974 44350151
 pgulf@qatar.net.qa

AUMA Saudi Arabia Support Office
SA 31952 Al Khobar
 Tel + 966 5 5359 6025
 Vinod.Fernandes@auma.com

AUMA ACTUATORS (Singapore) Pte Ltd.
SG 569551 Singapore
 Tel +65 6 4818750
 sales@auma.com.sg
 www.auma.com.sg

NETWORK ENGINEERING
SY Homs
 +963 31 231 571
 eyad3@scs-net.org

Sunny Valves and Intertrade Corp. Ltd.
TH 10120 Yannawa, Bangkok
 Tel +66 2 2400656
 mainbox@sunnyvalves.co.th
 www.sunnyvalves.co.th

Top Advance Enterprises Ltd.
TW Zhonghe City, Taipei Hsien (235)
 Tel +886 2 2225 1718
 support@auma-taiwan.com.tw
 www.auma-taiwan.com.tw

AUMA Vietnam Hanoi RO
VN Hanoi
 +84 4 37822115
 chiennguyen@auma.com.vn

Australia

BARRON GJM Pty. Ltd.
AU NSW 1570 Artarmon
 Tel +61 2 8437 4300
 info@barron.com.au
 www.barron.com.au

auma[®]

Solutions for a world in motion

AUMA Riester GmbH & Co. KG

P.O.Box 1362

DE 79373 Muellheim

Tel +49 7631 809 - 0

Fax +49 7631 809 - 1250

riester@auma.com

www.auma.com



Y005.019/003/en/1.15