

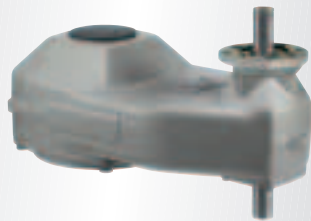

*Multi-turn gearboxes*  
Spur gearboxes  
GST 10.1 – 40.1



<b>Scope of these instructions:</b>	These instructions apply to multi-turn gearboxes of the type range: GST 10.1 – GST 40.1.
-------------------------------------	--

<b>Table of contents</b>	<b>Page</b>
<b>1. Safety instructions . . . . .</b>	<b>3</b>
1.1 Range of application	3
1.2 Maintenance	3
1.3 Warnings and notes	3
<b>2. Technical data . . . . .</b>	<b>4</b>
<b>3. Transport, storage and packaging. . . . .</b>	<b>6</b>
3.1 Transport	6
3.2 Storage	6
3.3 Packaging	6
<b>4. Fitting the handwheel . . . . .</b>	<b>6</b>
<b>5. Mounting multi-turn actuators SA/SAR . . . . .</b>	<b>7</b>
<b>6. Mounting to valve. . . . .</b>	<b>8</b>
<b>7. Operation of valves . . . . .</b>	<b>10</b>
<b>8. Enclosure protection IP 68 . . . . .</b>	<b>11</b>
<b>9. Maintenance . . . . .</b>	<b>12</b>
9.1 General references	12
9.2 Change of grease	13
<b>10. Disposal and recycling . . . . .</b>	<b>14</b>
<b>11. Service . . . . .</b>	<b>14</b>
<b>12. Spare parts list Spur gearboxes GST 10.1 – GST 16.1 . . . . .</b>	<b>16</b>
<b>13. Spur gearboxes GST 25.1 – GST 40.1 . . . . .</b>	<b>18</b>
<b>14. Declaration of Conformity and Declaration of Incorporation. . . . .</b>	<b>20</b>
<b>Index . . . . .</b>	<b>21</b>
<b>Addresses . . . . .</b>	<b>22</b>

## 1. Safety instructions

### 1.1 Range of application

AUMA spur gearboxes GST 10.1 – GST 40.1 are used for the operation of valves (e.g. gate valves and globe valves). They are designed for manual operation as well as motor operation in conjunction with electric actuators. For other applications, please consult AUMA. The manufacturer is not liable for any possible damage resulting from use in other than the designated applications. Such risk lies entirely with the user. Observance of these operation instructions is considered as part of the designated use. Explosion-proof products are specially marked. The service conditions mentioned in these operation instructions and in the technical data sheet have to be respected during use. Other service conditions require explicit and written confirmation by the manufacturer.

### 1.2 Maintenance

The maintenance instructions (refer to page 13) must be observed, otherwise a safe operation of the spur gearbox is no longer guaranteed.

### 1.3 Warnings and notes

Failure to observe the warnings and notes may lead to serious injuries or damage. Qualified personnel must be thoroughly familiar with all warnings and notes in these operation instructions. Correct transport, proper storage, mounting and installation, as well as careful commissioning are essential to ensure a trouble-free and safe operation. The following references draw special attention to safety-relevant procedures in these operation instructions. Each is marked by the appropriate pictograph.



**This pictograph means: Note!**

“Note” marks activities or procedures which have major influence on the correct operation. Non-observance of these notes may lead to consequential damage.



**This pictograph means: Warning!**

“Warning” marks activities or procedures which, if not carried out correctly, can affect the safety of persons or material.

## 2. Technical data

Features and functions																																																																																																																																										
Type of duty	Short-time duty S2 - 15 min. (open-close duty) Intermittent duty S4 - 25 % (modulating duty)																																																																																																																																									
Direction of rotation	Standard: Clockwise rotation at input shaft results in clockwise rotation at output shaft Option: GST 10.1 – GST 30.1 Reversal of rotation direction using a reversing gearbox GW 14.1																																																																																																																																									
Stages	One stage: GST 10.1 – GST 16.1 Double stage: GST 25.1 – GST 40.1																																																																																																																																									
Input shaft	GST 10.1 - GST 40.1: For standard reduction ratios, the input shaft is made of stainless steel. Exceptions: GST 16.1 5.6 : 1 GST 40.1 22 : 1 und 16 : 1 Standard: Cylindrical with parallel key according to DIN 6885.1 Option <sup>1)</sup> : Square - tapered (DIN 3233) - cylindrical																																																																																																																																									
Output torques	<table border="1"> <thead> <tr> <th rowspan="2">Type</th> <th colspan="2">Output torque</th> <th rowspan="2">Reduction ratio</th> <th colspan="2">Input torque <sup>2)</sup></th> <th rowspan="2">Factor<sup>3)</sup></th> </tr> <tr> <th>Nominal torque max. Nm</th> <th>Modulating torque max. Nm</th> <th>Nominal torque Nm</th> <th>Modulating torque Nm</th> </tr> </thead> <tbody> <tr> <td rowspan="3">GST 10.1</td> <td rowspan="3">120</td> <td rowspan="3">60</td> <td>1 : 1</td> <td>135</td> <td>66</td> <td>0.9</td> </tr> <tr> <td>1.4 : 1</td> <td>95</td> <td>46</td> <td>1.3</td> </tr> <tr> <td>2 : 1</td> <td>67</td> <td>33</td> <td>1.8</td> </tr> <tr> <td rowspan="3">GST 14.1</td> <td rowspan="3">250</td> <td rowspan="3">120</td> <td>1.4 : 1</td> <td>198</td> <td>92</td> <td>1.3</td> </tr> <tr> <td>2 : 1</td> <td>139</td> <td>66</td> <td>1.8</td> </tr> <tr> <td>2.8 : 1</td> <td>99</td> <td>48</td> <td>2.5</td> </tr> <tr> <td rowspan="3">GST 14.5</td> <td rowspan="3">500</td> <td rowspan="3">200</td> <td>2 : 1</td> <td>278</td> <td>111</td> <td>1.8</td> </tr> <tr> <td>2.8 : 1</td> <td>198</td> <td>80</td> <td>2.5</td> </tr> <tr> <td>4 : 1</td> <td>139</td> <td>55</td> <td>3.6</td> </tr> <tr> <td rowspan="3">GST 16.1</td> <td rowspan="3">1,000</td> <td rowspan="3">400</td> <td>2.8 : 1</td> <td>397</td> <td>160</td> <td>2.5</td> </tr> <tr> <td>4 : 1</td> <td>278</td> <td>111</td> <td>3.6</td> </tr> <tr> <td>5.6 : 1</td> <td>198</td> <td>80</td> <td>5.0</td> </tr> <tr> <td rowspan="3">GST 25.1</td> <td rowspan="3">2,000</td> <td rowspan="3">800</td> <td>4 : 1</td> <td>556</td> <td>222</td> <td>3.6</td> </tr> <tr> <td>5.6 : 1</td> <td>397</td> <td>160</td> <td>5.0</td> </tr> <tr> <td>8 : 1</td> <td>278</td> <td>111</td> <td>7.2</td> </tr> <tr> <td rowspan="3">GST 30.1</td> <td rowspan="3">4,000</td> <td rowspan="3">1,600</td> <td>5.6 : 1</td> <td>794</td> <td>320</td> <td>5.0</td> </tr> <tr> <td>8 : 1</td> <td>556</td> <td>222</td> <td>7.2</td> </tr> <tr> <td>11 : 1</td> <td>404</td> <td>162</td> <td>9.9</td> </tr> <tr> <td rowspan="3">GST 35.1</td> <td rowspan="3">8,000</td> <td rowspan="3">-</td> <td>8 : 1</td> <td>1,111</td> <td>-</td> <td>7.2</td> </tr> <tr> <td>11 : 1</td> <td>808</td> <td>-</td> <td>9.9</td> </tr> <tr> <td>16 : 1</td> <td>556</td> <td>-</td> <td>14.4</td> </tr> <tr> <td rowspan="3">GST 40.1</td> <td rowspan="3">16,000</td> <td rowspan="3">-</td> <td>11 : 1</td> <td>1,616</td> <td>-</td> <td>9.9</td> </tr> <tr> <td>16 : 1</td> <td>1,111</td> <td>-</td> <td>14.4</td> </tr> <tr> <td>22 : 1</td> <td>808</td> <td>-</td> <td>19.8</td> </tr> </tbody> </table>							Type	Output torque		Reduction ratio	Input torque <sup>2)</sup>		Factor <sup>3)</sup>	Nominal torque max. Nm	Modulating torque max. Nm	Nominal torque Nm	Modulating torque Nm	GST 10.1	120	60	1 : 1	135	66	0.9	1.4 : 1	95	46	1.3	2 : 1	67	33	1.8	GST 14.1	250	120	1.4 : 1	198	92	1.3	2 : 1	139	66	1.8	2.8 : 1	99	48	2.5	GST 14.5	500	200	2 : 1	278	111	1.8	2.8 : 1	198	80	2.5	4 : 1	139	55	3.6	GST 16.1	1,000	400	2.8 : 1	397	160	2.5	4 : 1	278	111	3.6	5.6 : 1	198	80	5.0	GST 25.1	2,000	800	4 : 1	556	222	3.6	5.6 : 1	397	160	5.0	8 : 1	278	111	7.2	GST 30.1	4,000	1,600	5.6 : 1	794	320	5.0	8 : 1	556	222	7.2	11 : 1	404	162	9.9	GST 35.1	8,000	-	8 : 1	1,111	-	7.2	11 : 1	808	-	9.9	16 : 1	556	-	14.4	GST 40.1	16,000	-	11 : 1	1,616	-	9.9	16 : 1	1,111	-	14.4	22 : 1	808	-	19.8
Type	Output torque		Reduction ratio	Input torque <sup>2)</sup>		Factor <sup>3)</sup>																																																																																																																																				
	Nominal torque max. Nm	Modulating torque max. Nm		Nominal torque Nm	Modulating torque Nm																																																																																																																																					
GST 10.1	120	60	1 : 1	135	66	0.9																																																																																																																																				
			1.4 : 1	95	46	1.3																																																																																																																																				
			2 : 1	67	33	1.8																																																																																																																																				
GST 14.1	250	120	1.4 : 1	198	92	1.3																																																																																																																																				
			2 : 1	139	66	1.8																																																																																																																																				
			2.8 : 1	99	48	2.5																																																																																																																																				
GST 14.5	500	200	2 : 1	278	111	1.8																																																																																																																																				
			2.8 : 1	198	80	2.5																																																																																																																																				
			4 : 1	139	55	3.6																																																																																																																																				
GST 16.1	1,000	400	2.8 : 1	397	160	2.5																																																																																																																																				
			4 : 1	278	111	3.6																																																																																																																																				
			5.6 : 1	198	80	5.0																																																																																																																																				
GST 25.1	2,000	800	4 : 1	556	222	3.6																																																																																																																																				
			5.6 : 1	397	160	5.0																																																																																																																																				
			8 : 1	278	111	7.2																																																																																																																																				
GST 30.1	4,000	1,600	5.6 : 1	794	320	5.0																																																																																																																																				
			8 : 1	556	222	7.2																																																																																																																																				
			11 : 1	404	162	9.9																																																																																																																																				
GST 35.1	8,000	-	8 : 1	1,111	-	7.2																																																																																																																																				
			11 : 1	808	-	9.9																																																																																																																																				
			16 : 1	556	-	14.4																																																																																																																																				
GST 40.1	16,000	-	11 : 1	1,616	-	9.9																																																																																																																																				
			16 : 1	1,111	-	14.4																																																																																																																																				
			22 : 1	808	-	19.8																																																																																																																																				
Operation																																																																																																																																										
Motor operation	With electric multi-turn actuator, directly flanges for mounting the multi-turn actuator, refer to separate technical data sheets.																																																																																																																																									
Manual operation	Standard: Via handwheel, directly																																																																																																																																									
	<table border="1"> <thead> <tr> <th>Type</th> <th>GST 10.1</th> <th>GST 14.1</th> <th>GST 14.5</th> <th>GST 16.1</th> <th>GST 25.1</th> <th>GST 30.1</th> <th>GST 35.1</th> <th>GST 40.1</th> </tr> </thead> <tbody> <tr> <td>Handwheel mm</td> <td>200</td> <td>315 (250)</td> <td>315</td> <td>400</td> <td>500</td> <td>500</td> <td>500</td> <td>500</td> </tr> </tbody> </table>							Type	GST 10.1	GST 14.1	GST 14.5	GST 16.1	GST 25.1	GST 30.1	GST 35.1	GST 40.1	Handwheel mm	200	315 (250)	315	400	500	500	500	500																																																																																																																	
Type	GST 10.1	GST 14.1	GST 14.5	GST 16.1	GST 25.1	GST 30.1	GST 35.1	GST 40.1																																																																																																																																		
Handwheel mm	200	315 (250)	315	400	500	500	500	500																																																																																																																																		
	Option: Remote extension shaft (not contained within the AUMA product range)																																																																																																																																									
Valve attachment																																																																																																																																										
Output drive types	A, B1, B2, B3, B4 according to EN ISO 5210 A, B, D, E according to DIN 3210 C according to DIN 3338 Special output drives: AF, AK, AG, IB1, IB3, IB4																																																																																																																																									
<p>1) For size, please contact AUMA</p> <p>2) At max. output torque</p> <p>3) Conversion factor for output torque to input torque</p>																																																																																																																																										

<b>Service conditions</b>	
Mounting position	Any position
Enclosure protection according to EN 60 529	Standard: IP 67 Options: IP 68 (also refer to page 12)
Corrosion protection	Standard: KN Suitable for installation in industrial units, in water or power plants with a low pollutant concentration Options: KS Suitable for installation in occasionally or permanently aggressive atmosphere with a moderate pollutant concentration (e.g. wastewater treatment plants, chemical industry) KX Suitable for installation in extremely aggressive atmosphere with high humidity and high pollutant concentration
Finish coating	Standard: Two-component iron-mica combination
Colour	Standard: AUMA silver-grey (similar to RAL 7037) if finish-painted Option: Other colours on request
Ambient temperature	Standard: -40 °C to +80 °C Options: -60 °C to +60 °C (extreme low temperature), version EL -0 °C to +120 °C (high temperature), version H
Lifetime	Open-close duty: Operations (OPEN - CLOSE - OPEN) with 30 turns per stroke GST 10.1: 20,000 operations GST 14.1 – 16.1: 15,000 operations GST 25.1 – 30.1: 10,000 operations GST 35.1 – 40.1: 5,000 operations Modulating duty <sup>4)</sup> : GST 10.1: 5.0 million modulating steps GST 14.1 – 16.1: 3.5 million modulating steps GST 25.1 – 30.1: 2.5 million modulating steps
<b>Accessories</b>	
Limit switching	Limit switching device WSH for manually operated valves. For the signalling of intermediate and end positions (refer to separate data sheet).
Reversing gearboxes	Reversing gearbox GW for reversing the rotation direction for manual and motor operation
<b>Special features for use in potentially explosive atmospheres</b>	
Explosion protection	II2G c IIC T4 in compliance with ATEX 94/9/EC
Type of duty <sup>5)</sup>	During open-close duty: Short-time duty S2 - 15 min. at 50 % of maximum nominal output torque up to GST 14.5 and at 35 % of maximum nominal output torque from GST 16.1  During modulating duty: Intermittent duty S4 - 25 % at maximum modulating torque
Ambient temperature	Standard: -40 °C to +60 °C Options: -60 °C to +60 °C (extreme low temperature) Combinations with actuators SAExC at ambient temperatures > 40 °C with special sizing.
<b>Further information</b>	
Reference documents	Product description Spur gearboxes GST 10.1 – GST 40.1 Dimension sheet GST 10.1 – GST 40.1 Technical data GST 10.1 – GST 40.1 Technical data SA/SAR Technical data GW Technical data WSH
<p>4) The lifetime for modulating duty depends on the load and the number of starts. A high starting frequency will rarely improve the modulating accuracy. To reach the longest possible maintenance and fault-free operation time, the number of starts per hour chosen should be as low as permissible for the process</p> <p>5) The type of duty must not be exceeded.</p>	

### 3. Transport, storage and packaging

#### 3.1 Transport

- Transport to place of installation in sturdy packing.
- If mounted together with actuator:  
Attach ropes or hooks for the purpose of lifting by hoist only to the gearbox and not to the actuator.

#### 3.2 Storage

- Store in well-ventilated, dry room.
- Protect against floor dampness by storage on a shelf or on a wooden pallet.
- Cover to protect against dust and dirt.
- Apply suitable corrosion protection agent to uncoated surfaces.

In case gearboxes are to be stored for a long period (more than 6 months), the following points must be observed additionally:

- Prior to storage: Protect uncoated surfaces, in particular the output drive parts and mounting surface, with long-term corrosion protection agent.
- Check for corrosion approximately every 6 months. If first signs of corrosion show, apply new corrosion protection.

#### 3.3 Packaging

Our products are protected by special packaging for the transport ex works. The packaging consists of environmentally friendly materials which can easily be separated and recycled.

For the disposal of the packaging material, we recommend recycling and collection centres.

We use the following packaging materials:

Wooden material boards (OSB)/cardboard/paper/PE film

### 4. Fitting the handwheel

For gearboxes designed for manual operation, the handwheel is supplied separately. Fitting is done on site according to figure 1.

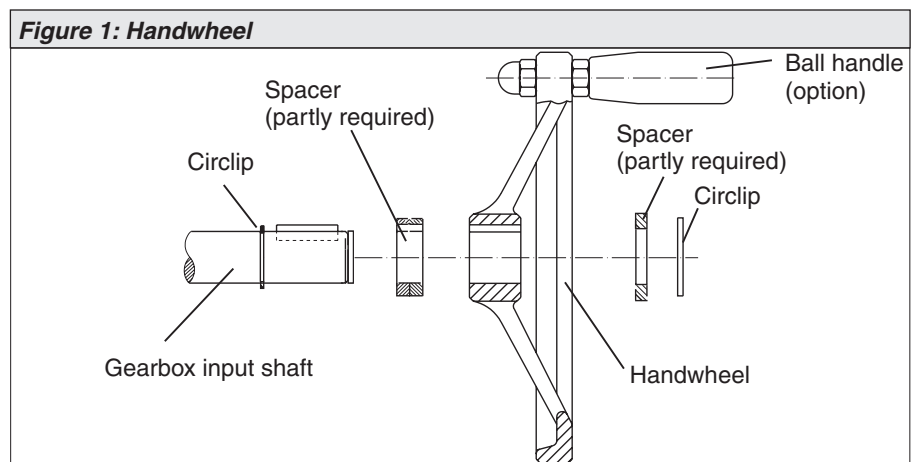

## 5. Mounting multi-turn actuators SA/SAR

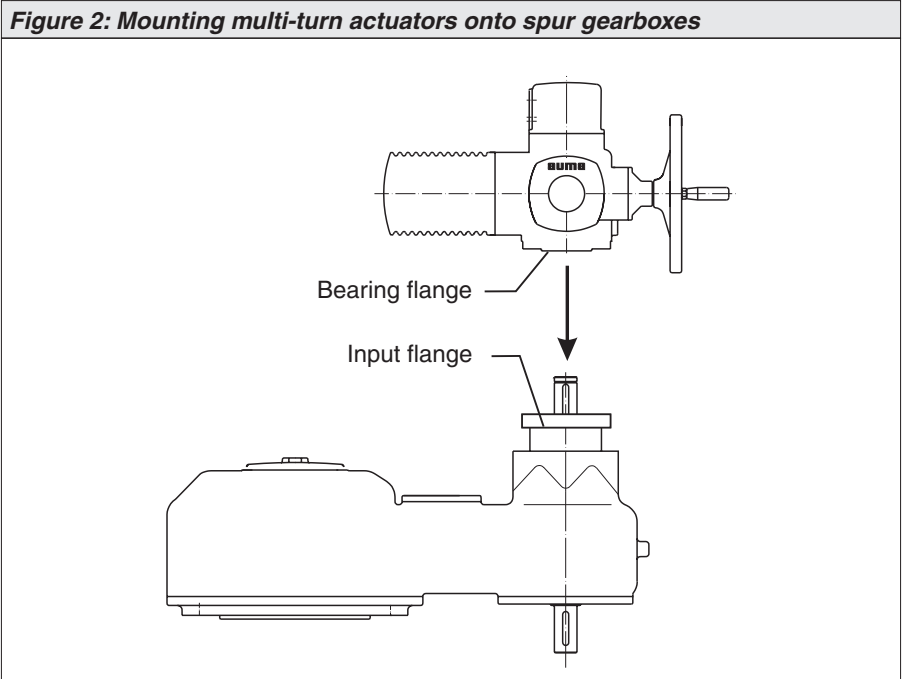

### Mounting the multi-turn actuator:

- Thoroughly degrease the faces of the bearing flange at actuator and of the input flange at spur gearbox.
- Place the multi-turn actuator on the spur gearbox.
- Ensure that the spigot mates uniformly in the recess and that the mounting faces are in complete contact.
- Fasten actuator with screws (see table 1) at the flange of the spur gearbox.
- Fasten screws crosswise with a torque according to table 2.



**Do not attach ropes or hooks for the purpose of lifting the actuator by hoist to the handwheel. If multi-turn actuator is mounted on gearbox, attach ropes or hooks for the purpose of lifting by hoist to gearbox and not to multi-turn actuator.**

**Table 1: screws for mounting AUMA multi-turn actuators on spur gearbox**

Gearbox	SA(R) 07.5-F10/G0		SA(R) 10.1-F10/G0		SA(R) 14.1-F14/G1/2	
	Screw	Pcs.	Screw	Pcs.	Screw	Pcs.
GST 10.1	M 10 x 25	4	M 10 x 25	4	M 16 x 40	4
GST 14.1			M 10 x 25	4	M 16 x 40	4
GST 14.5			M 10 x 25	4	M 16 x 40	4
GST 16.1					M 16 x 40	4
GST 25.1					M 16 x 40	4
Gearbox	SA(R) 14.5-F14/G1/2		SA(R) 16.1-F16/G3		SA(R) 25.1-F25/G4	
	Screw	Pcs.	Screw	Pcs.	Screw	Pcs.
GST 14.5	M 16 x 40	4				
GST 16.1	M 16 x 40	4				
GST 25.1	M 16 x 40	4	M 20 x 50	4		
GST 30.1	M 16 x 40	4	M 20 x 50	4		
GST 35.1	M 16 x 40	4	M 20 x 50	4	M 16 x 50	8
GST 40.1			M 20 x 50	4	M 16 x 50	8

## 6. Mounting to valve

The gearboxes can be operated in any mounting position.



- Prior to mounting, the gearbox must be checked for damage. Damaged parts must be replaced by original spare parts.
- After mounting to valve, touch up any possible damage to paint finish.

Mount gearbox to valve (with output drive types B1 – B4 or E)

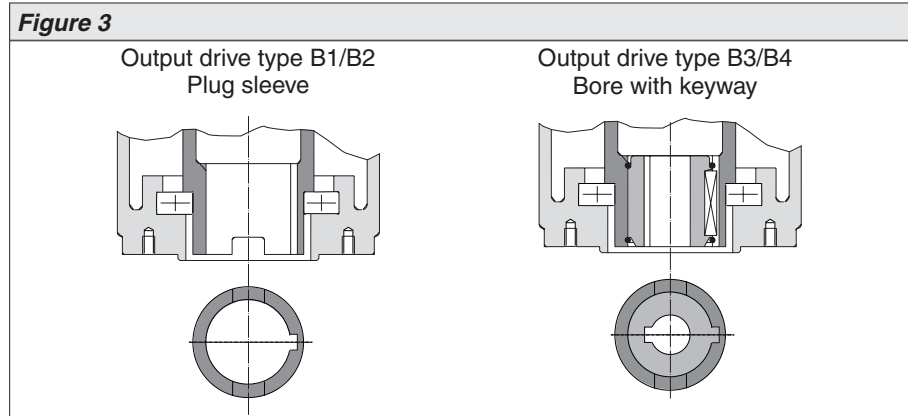

- Check whether mounting flanges match.
- Check whether bore and keyway match the input shaft of the valve.
- Apply a small quantity of grease to input shaft of valve..
- Fit gearbox.

**Information:** Ensure that the spigot fits uniformly in the recess and that the mounting faces are in complete contact

- Fasten with screws of minimum quality 8.8 according to table 2.

**Information:** We recommend applying liquid thread sealing material to the screws to avoid contact corrosion.

- Fasten screws crosswise to a torque according to table 2.

**Table 2: Fastening torques for screws**

Thread	Fastening torque $T_A$ [Nm]		
	Strength class		
	8.8	A2-70/A4-70	A2-80/A4-80
M 8	25	18	24
M10	50	36	48
M12	87	61	82
M16	214	150	200
M20	431	294	392
M30	1,489	564	–
M36	2,594	–	–



### Output drive type A

Application:

- Output drive for rising, non-rotating valve stem
- Suitable for accepting thrust

#### Finish machining of stem nut

This working stop is only required if stem nut is supplied unbored or with pilot bore.

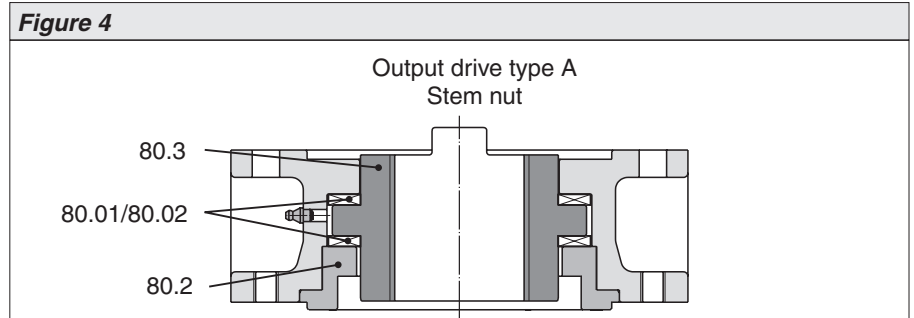

The output drive flange does not have to be removed from the gearbox.

- Remove spigot ring (80.2, figure 4) from output drive.
- Remove stem nut (80.3) together with bearings (80.01 and 80.02).
- Remove bearing races (80.02) and bearing rims (80.01) from stem nut (80.3).
- Bore and drill stem nut (80.03) and cut thread.
- **Information:** When fixing in the chuck, make sure stem nut runs true!
- Clean the machined stem nut (80.3).
- Apply sufficient Lithium soap EP multi-purpose grease to bearing rims (80.01) and bearing races (80.02) ensuring that all hollow spaces are filled with grease.
- Place greased bearing rims (80.01) and bearing races (80.02) on stem nut (80.3).
- Re-insert stem nut (80.3) with bearings (80.01 and 80.02) into output drive.
- **Information:** Ensure that dogs or splines are placed correctly in the keyway of the hollow shaft.
- Screw in spigot ring (80.2) until it is firm against the shoulder.

### Mount gearbox (with output drive type A) to valve

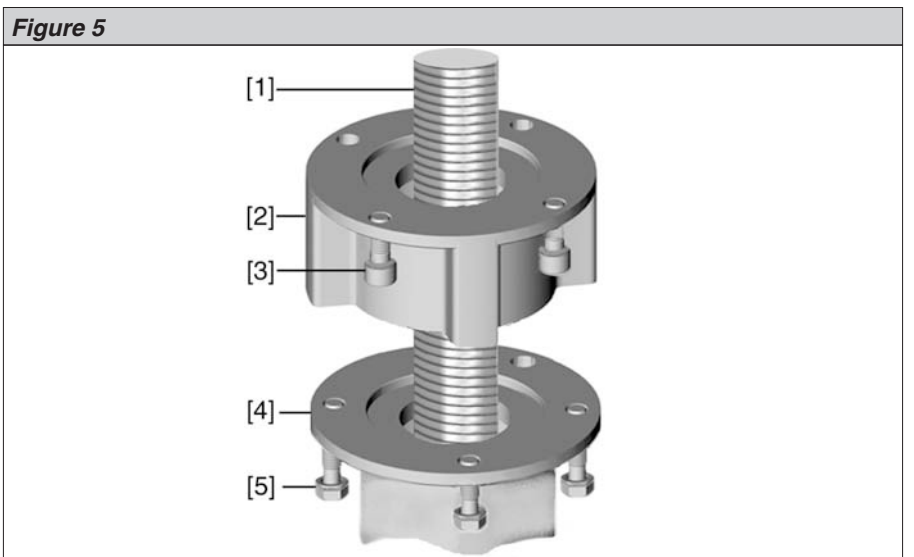

- [1] Valve stem
- [2] Output drive type A
- [3] Screws to actuator
- [4] Valve flange
- [5] Screws to output drive

- If the output drive type A is already mounted to the gearbox: Loosen screws [3] and remove output drive type A [2].
- Check if the flange of output drive type A matches the valve flange [4].
- Apply a small quantity of grease to the valve stem [1].
- Place output drive type A on the valve stem and turn until it is flush on the valve flange.
- Turn output drive type A until alignment of the fixing holes.
- Screw in fastening screws [5], however do not completely tighten.
- Fit gearbox on the valve stem so that the stem nut dogs engage into the output socket.

**The flanges are flush with each other if properly engaged.**

- Adjust gearbox until alignment of the fixing holes.
- Fasten gearbox with screws [3].
- Fasten screws [3] crosswise with a torque according to table 2.
- Turn gearbox and actuator with handwheel in direction OPEN until valve flange and output drive type A are firmly placed together.
- Tighten fastening screws [5] between valve and output drive type A crosswise applying a torque according to table 2.

**Table 3: Grease quantities bearings output drive type A**

Output drive	A 07.2	A 10.2	A 14.2	A 16.2	A 25.2	A 30.2	A 35.2	A 40.2
Qty <sup>1)</sup>	1.5 g	2 g	3 g	5 g	10 g	14 g	20 g	25 g

1) For grease with density  $\rho = 0.9 \text{ kg/dm}^3$

**Protection tube for rising valve stem**

- Seal thread of protection tube with hemp, Teflon tape, or thread sealing material.
- Screw protection tube (1) into thread (figure 6) and tighten it firmly.
- Push down the sealing (2) to the housing.
- Check whether cap (3) is available and without damage.
- 

**Figure 6: Protection tube for rising valve stem**

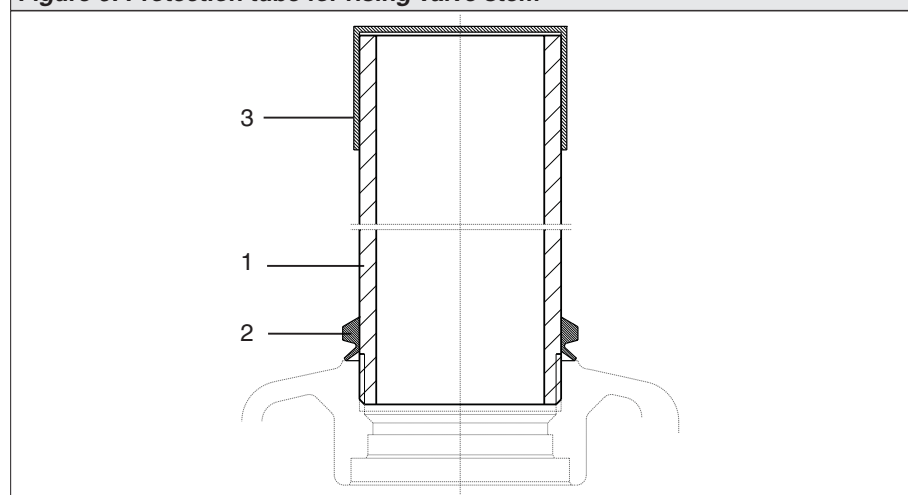

## 7. Operation of valves

The max. output torque (refer to technical data, page 4 or name plate) refers to the peak values and should not be applied over the whole travel.

Clockwise rotation at input shaft results in clockwise rotation at output drive

### For motor operation:

- Observe operation instructions pertaining to multi-turn actuator.
- The setting of the torque switching within the multi-turn actuator may not exceed the max. permissible input torque for both directions (refer to technical data, page 4, or name plate).
- Set the torque switching within the multi-turn actuator to the following value to prevent any damage to the valve:

$$T_{\text{Torque switch}} = \frac{T_{\text{Valve}}}{\text{Factor}}$$

Factor = Conversion factor from output torque to input torque.  
Refer to values in technical data, page 4.

## 8. Enclosure protection IP 68

### Definition

According to EN 60529, the conditions for meeting the requirements of enclosure protection IP 68 are to be agreed between manufacturer and user.

AUMA gearboxes in enclosure protection IP 68 fulfil the following requirements in compliance with AUMA definitions:

- Head of water max. 6 m.

If submersed in other media, additional measures for corrosion protection may be necessary; please consult AUMA. Submersion in aggressive media, e.g. acids or alkaline solutions, is not permitted.

### Inspection

AUMA gearboxes in enclosure protection IP 68 undergo a routine testing for tightness in the factory.

### After submersion

- Check gearbox.
- In case of ingress of water, dry actuator correctly and check for proper function.

### Notes

- The enclosure protection IP 68 refers to the interior of the gearbox.
- If the gearboxes are likely to be repeatedly submersed, a higher corrosion protection KS or KX is required.
- We strongly recommend to select the higher corrosion protection KS or KX for gearboxes for buried service.
- Use suitable sealing material between valve flange and gearbox.
- Stem protection tubes and telescopic protection tubes should not be used during submersion, instead use a screw plug made of aluminium.
- When using output drive types A and AF (stem nut), it cannot be prevented that during submersion water enters the bore of the hollow shaft along the thread of the valve stem. This leads to corrosion. The water also enters the thrust bearings of output drive type A, causing corrosion and damage of the bearings. The output drive types A and AF should therefore not be used for gearboxes in enclosure protection IP 68.
- For submersion in water, AUMA recommends to use grease suitable for use in drinking water.
- For continuous submersion, the seals should be changed at shorter intervals.

## 9. Maintenance

### 9.1 General references

After commissioning, check gearbox for damage to paint finish. Do a thorough touch-up to prevent corrosion. Original paint in small quantities can be supplied by AUMA.

AUMA gearboxes require only very little maintenance. To ensure that the gearbox is always ready to operate, we recommend – provided that on an average not more than 10 operations are performed per year – the following measures:

- Approximately six months after commissioning and then every year check screws between multi-turn actuator, gearbox, and valve for tightness. If required, tighten applying the torques given in table 2 (page 8).
- Perform a test run as well as a visual inspection for grease leakage every six months.
- Carry out a detailed functional test for each gearbox every 5 years. Record the results for future reference.
- For gearboxes permanently exposed to ambient temperatures above 40 °C, maintenance must be performed at shorter intervals.
- For gearboxes with output drive type A: at intervals of approx. six months from commissioning, press in Lithium soap EP multi-purpose grease on mineral oil base at the grease nipple with grease gun (for quantity, refer to table 3, page 10).

#### Seals:

The seals must be changed when changing the grease. Seal kits may be obtained from AUMA.

#### Grease:

A grease and seal change is recommended after the following operation times:

- if operated seldom, after 10 – 12 years
- if operated frequently, after 6 – 8 years



- Only original AUMA grease must be used.
- For the grease type, refer to the name plate: Standard F1
- Lubricants should not be mixed.

**Table 4: Grease quantities for spur gearboxes**

GST		10.1	14.1	14.5	16.1	25.1	30.1	35.1	40.1
Qty	dm <sup>3</sup>	0.8	1.54	1.54	3.1	6.3	12.1	22.0	22.2
Weight <sup>1)</sup>	kg	0.7	1.4	1.4	2.8	5.7	11.0	20.0	20.2

1) for  $\rho$  = approx. 0.9 kg/dm<sup>3</sup>



The removed lubricant and the cleaning agent used must be disposed of according to the relevant regulations.



For safe operation of explosion-proof products, the gear housing has to be lubricated in compliance with the manufacturer specifications. In the event of lubricant loss, repair measures have to be initiated without delay.

## 9.2 Change of grease

- For gearboxes with multi-turn actuator: Remove multi-turn actuator.
- Remove gearbox from the valve:



**During this time, the valve/pipeline must not be under pressure!**

- Mark position of the gearbox on the valve, loosen connecting screws to the valve and remove the gearbox.

### Remove old grease:

Grease type, see name plate; grease quantities, see page 13, table 4. The numbers used in the following text refer to the spare parts list(s) of these operation instructions.

- Remove screws at bearing flange (002.0).
- Remove mounting flange assembly with hollow shaft (003.0) from the housing.
- Remove old grease completely from the housing and the individual parts and clean gear housing. For this purpose, kerosene or a similar cleaning agent may be used.
- Replace seals S1 by new ones.
- Clean mounting faces at housing and bearing flange and apply a small quantity of grease.
- Mount bearing flange (002.0) with hollow shaft (003.0) into housing, whilst paying attention to the O-ring S1 (006 or 008) at the bearing flange and O-ring S1 in the housing.  
Screw in screws with and fasten them evenly crosswise to the appropriate torque according to table 2, page 8.

### Fill with new grease:

- Remove screws at bearing flange of the input shaft (010.0-1 or 010.0-2).
- Remove bearing flange.
- Fill with new grease.
- Clean mounting faces at housing and bearing flange and apply a small quantity of grease.
- Fit bearing flange (010.0-1 or 010.0-2) with new O-ring S1. Screw in screws with and fasten them evenly crosswise to the appropriate torque according to table 2, page 8.

### After maintenance:

- Fasten gearbox to valve again.
- If applicable, mount multi-turn actuator.
- For gearboxes with multi-turn actuator, check the setting of the limit switching according to the operation instructions for multi-turn actuators; if required, re-set.
- Perform test run to ensure the proper function.
- Check the gearbox for damage to paint finish. Do a thorough touch-up to prevent corrosion. Original paint in small quantities can be supplied by AUMA.

## 10. Disposal and recycling

AUMA gearboxes have an extremely long lifetime. However, they have to be replaced at one point in time.

Our gearboxes have a modular design and may therefore easily be disassembled, separated and sorted according to materials, i.e.:

- various metals
- plastics
- greases and oils

The following generally applies:

- Collect greases and oils during disassembly. As a rule, these substances are hazardous to water and must not be released into the environment.
- Arrange for controlled waste disposal of the disassembled material or for separate recycling according to materials.
- Observe the national regulations for waste disposal.

## 11. Service

AUMA offers extensive services such as maintenance and inspection for gearboxes. Addresses of AUMA offices and representatives can be found on page 22 and on the Internet ([www.auma.com](http://www.auma.com)).

12. Spare parts list Spur gearboxes GST 10.1 – GST 16.1

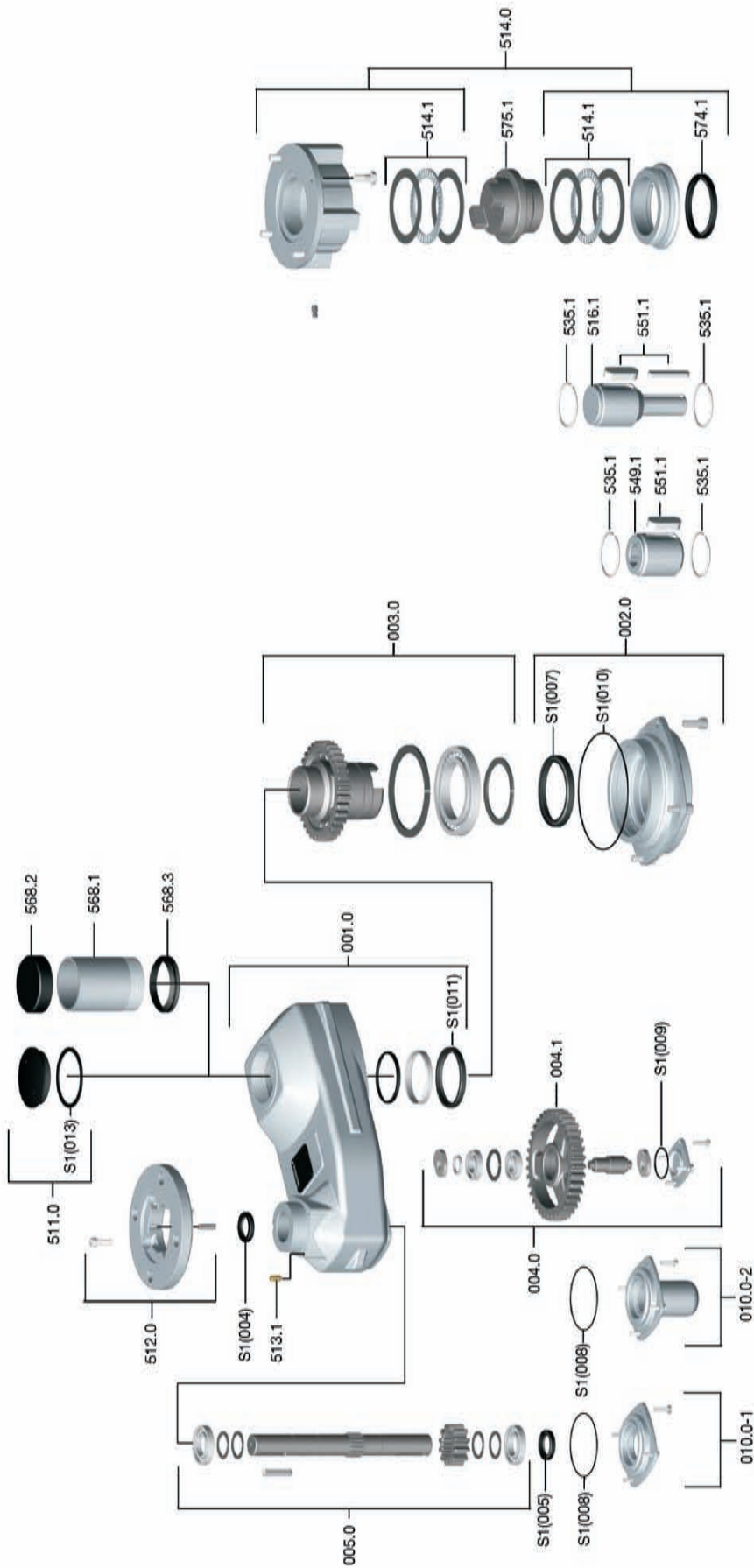



**Note:** Please state type and commission no. of the device (see name plate) when ordering spare parts. Only original AUMA spare parts may be used.

Delivered spare parts may slightly vary from the representation in these instructions.

No.	Designation	Type
001.0	Housing	Sub-assembly
002.0	Bearing flange	Sub-assembly
003.0	Hollow shaft	
004.0	Intermediate stage	Sub-assembly
004.1	Intermediate wheel	
005.0	Input shaft	Sub-assembly
010.0-1	Input shaft bearing flange	Sub-assembly
010.0-2	Input shaft bearing flange with protection cover	Sub-assembly
511.0	Screw plug	Sub-assembly
512.0	Flange for actuator	Sub-assembly
513.1	Grub screw	
514.0	Output drive form A (without stem nut)	Sub-assembly
514.1	Axial needle roller bearing	Sub-assembly
516.1	Output drive shaft D	
535.1	Snap ring	
549.1	Output socket B3/B4/E	
551.1	Parallel key	
568.1	Stem protection tube (without cap)	
568.2	Cap for stem protection tube	
568.3	V-seal	
574.1	Radial seal output drive A for ISO flange	
575.1	Stem nut type A	
S1	Seal kit	Set

### 13. Spur gearboxes GST 25.1 – GST 40.1

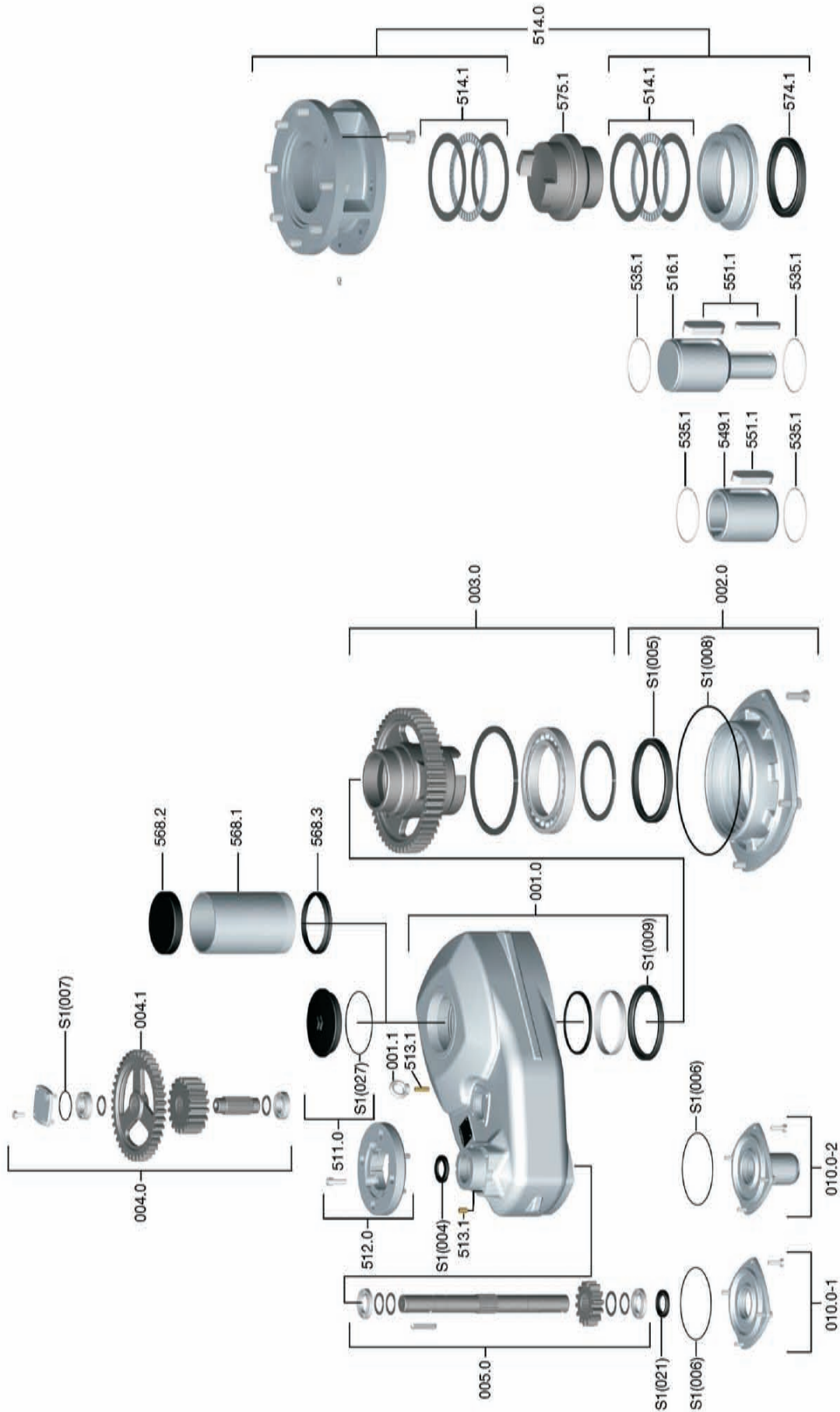

**Note:** Please state type and commission no. of the device (see name plate) when ordering spare parts. Only original AUMA spare parts may be used.

Delivered spare parts may slightly vary from the representation in these instructions.

No.	Designation	Type
001.0	Housing	Sub-assembly
001.1	Ring nut	
002.0	Bearing flange	Sub-assembly
003.0	Hollow shaft	Sub-assembly
004.0	Intermediate stage	Sub-assembly
004.1	Intermediate wheel	
005.0	Input shaft	Sub-assembly
010.0-1	Input shaft bearing flange	Sub-assembly
010.0-2	Input shaft bearing flange with protection cover	Sub-assembly
511.0	Screw plug	Sub-assembly
512.0	Flange for actuator	Sub-assembly
513.1	Grub screw	
514.0	Output drive form A (without stem nut)	Sub-assembly
514.1	Axial needle roller bearing, from GST 35.1: axial cylinder roller bearing	Sub-assembly
516.1	Output drive shaft D	
535.1	Snap ring	
549.1	Output socket B3/B4/E	
551.1	Parallel key	
568.1	Stem protection tube	
568.2	Cap for stem protection tube	
568.3	V-seal	
574.1	Radial seal output drive A for ISO flange	
575.1	Stem nut type A	
S1	Seal kit	Set

## 14. Declaration of Conformity and Declaration of Incorporation

AUMA Riester GmbH & Co. KG    Tel +49 7631 809-0  
 Aumastr. 1    Fax +49 7631 809-1250  
 79379 Müllheim, Germany    Riester@auma.com  
 www.auma.com



### Original Declaration of Incorporation of Partly Completed Machinery (EC Directive 2006/42/EC) and EC Declaration of Conformity in compliance with the Directive on Explosion Protection

for AUMA gearboxes of the type ranges

<b>Worm gearboxes</b>	GS 50.3 – GS 125.3 with reduction gearing VZ 2.3 – VZ 4.3 GS 160.3 – GS 250.3 with reduction gearing GZ 160.3 – GZ 250.3 GS 630.3 with reduction gearing GZ 630.3
<b>Lever gearboxes</b>	GS 315 – GS 500 with reduction gearing GZ 16.1 – GZ 40.1 GF 50.3 – GF 125.3 with reduction gearing VZ 2.3 – VZ 4.3 GF 160.3 – GF 250.3 with reduction gearing GZ 160.3 – GZ 250.3
<b>Bevel gearboxes</b>	GK 10.2 – GK 40.2
<b>Spur gearboxes</b>	GST 10.1 – GST 40.1

AUMA Riester GmbH & Co. KG as manufacturer declares herewith, that the above mentioned gearboxes meet the following basic requirements of the EC Machinery Directive 2006/42/EC: Annex I, articles 1.1.2, 1.1.3, 1.1.5, 1.3.1, 1.3.7, 1.7.1, 1.7.3, 1.7.4

The following harmonised standards within the meaning of the Machinery Directive have been applied:

EN 12100-1: 2003	ISO 5210: 1996
EN 12100-2: 2003	ISO 5211: 2001

With regard to the partly completed machinery, the manufacturer commits to submitting the documents to the competent national authority via electronic transmission upon request. The relevant technical documentation pertaining to the machinery described in Annex VII, part B has been prepared.

AUMA gearboxes are designed to be installed on industrial valves. AUMA gearboxes must not be put service until the final machinery into which they are to be incorporated has been declared in conformity with the provisions of the EC Directive 2006/42/EC.

Authorised person for documentation: Peter Malus, Aumastrasse 1, D-79379 Müllheim

As partly completed machinery, the gearboxes further comply with the requirements of the following directives and the respective approximation of national laws as well as the respective harmonised standards as listed below:

#### (1) Equipment and protective systems intended for use in potentially explosive atmospheres (94/9/EC)

EN 1127-1: 2007
EN 13463-1: 2009
EN 13463-5: 2003

The above mentioned AUMA gearboxes in "ATEX" version are marked as follows:

**II2G c IIC T4 or T3**  
**II2D IP6X T130°C or T190°C**

In order to meet the requirements for use of AUMA gearboxes in potentially explosive atmospheres, the relevant information in the operation instructions must imperatively be observed.

Müllheim, 2009-12-29

  
 H. Newerla, General Management

This declaration does not contain any guarantees. The safety instructions in product documentation supplied with the devices must be observed. Non-concerted modification of the devices voids this declaration. Y004.932/002/en

**Index**

<b>B</b>		<b>M</b>		<b>T</b>	
Bolts for mounting multi-turn actuator	7	Maintenance	3,13	Technical data	4
<b>C</b>		Motor operation	4,11	Transport	6
Corrosion protection	6	Mounting of multi-turn actuators	7	Type of duty	4
<b>D</b>		Mounting to valve	8		
Declaration of Conformity	20	<b>O</b>			
Declaration of Incorporation	20	Output drive types	4		
Direction of rotation	4	Output torques	4		
Disposal and recycling	15	<b>P</b>			
<b>E</b>		Packaging	6		
Enclosure protection IP 68	12	Protection tube	10		
<b>F</b>		<b>S</b>			
Finish machining of stem nut	9	Safety instructions	3		
Fitting the handwheel	6	Service	15		
<b>H</b>		Spare parts lists			
Handwheel	6	GST 10.1 - GST 16.1	16		
<b>L</b>		GST 25.1 - GST 40.1	18		
Lubricant	14	Storage	6		

## Europe

### AUMA Riestler GmbH & Co. KG

Plant Müllheim  
**DE-79373 Müllheim**  
 Tel +49 7631 809 - 0  
 Fax +49 7631 809 - 1250  
 riestler@auma.com  
 www.auma.com

Plant Ostfildern-Nellingen  
**DE-73747 Ostfildern**  
 Tel +49 711 34803 - 0  
 Fax +49 711 34803 - 3034  
 riestler@wof.auma.com

Service-Center Köln  
**DE-50858 Köln**  
 Tel +49 2234 2037 - 9000  
 Fax +49 2234 2037 - 9099  
 Service@sck.auma.com

Service-Center Magdeburg  
**DE-39167 Niederndodeleben**  
 Tel +49 39204 759 - 0  
 Fax +49 39204 759 - 9429  
 Service@scm.auma.com

Service-Center Bayern  
**DE-85386 Eching**  
 Tel +49 81 65 9017- 0  
 Fax +49 81 65 9017- 2018  
 Riestler@scb.auma.com

AUMA Armaturentriebe GmbH  
**AT-2512 Tribuswinkel**  
 Tel +43 2252 82540  
 Fax +43 2252 8254050  
 office@auma.at  
 www.auma.at

AUMA (Schweiz) AG  
**CH-8965 Berikon**  
 Tel +41 566 400945  
 Fax +41 566 400948  
 RettichP.ch@auma.com

AUMA Servopohony spol. s.r.o.  
**CZ-250 01 Brandýs n.L.-St.Boleslav**  
 Tel +420 326 396 993  
 Fax +420 326 303 251  
 auma-s@auma.cz  
 www.auma.cz

OY AUMATOR AB  
**FI-02230 Espoo**  
 Tel +358 9 5840 22  
 Fax +358 9 5840 2300  
 auma@aumator.fi  
 www.aumator.fi

AUMA France S.A.R.L.  
**FR-95157 Taverny Cedex**  
 Tel +33 1 39327272  
 Fax +33 1 39321755  
 info@auma.fr  
 www.auma.fr

AUMA ACTUATORS Ltd.  
**GB- Clevedon North Somerset BS21 6TH**  
 Tel +44 1275 871141  
 Fax +44 1275 875492  
 mail@auma.co.uk  
 www.auma.co.uk

AUMA ITALIANA S.r.l. a socio unico  
**IT-20023 Cerro Maggiore (MI)**  
 Tel +39 0331 51351  
 Fax +39 0331 517606  
 info@auma.it  
 www.auma.it

AUMA BENELUX B.V.  
**NL-2314 XT Leiden**  
 Tel +31 71 581 40 40  
 Fax +31 71 581 40 49  
 office@benelux.auma.com  
 www.auma.nl

AUMA Polska Sp. z o.o.  
**PL-41-219 Sosnowiec**  
 Tel +48 32 783 52 00  
 Fax +48 32 783 52 08  
 biuro@auma.com.pl  
 www.auma.com.pl

OOO Priwody AUMA  
**RU- 124365 Moscow a/ya 11**  
 Tel +7 495 221 64 28  
 Fax +7 495 221 64 38  
 aumarussia@auma.ru  
 www.auma.ru

ERICH'S ARMATUR AB  
**SE-20039 Malmö**  
 Tel +46 40 311550  
 Fax +46 40 945515  
 info@erichsarmatur.se  
 www.erichsarmatur.se

GRØNBECH & SØNNER A/S  
**DK-2450 København SV**  
 Tel +45 33 26 63 00  
 Fax +45 33 26 63 21  
 GS@g-s.dk  
 www.g-s.dk

IBEROPLAN S.A.  
**ES-28027 Madrid**  
 Tel +34 91 3717130  
 Fax +34 91 7427126  
 iberoplan@iberoplan.com

D. G. Bellos & Co. O.E.  
**GR-13671 Acharnai Athens**  
 Tel +30 210 2409485  
 Fax +30 210 2409486  
 info@dgbellos.gr

SIGURD SØRUM A. S.  
**NO-1300 Sandvika**  
 Tel +47 67572600  
 Fax +47 67572610  
 post@sigum.no

INDUSTRA  
**PT-2710-297 Sintra**  
 Tel +351 2 1910 95 00  
 Fax +351 2 1910 95 99  
 industria@tyco-valves.com

MEGA Endüstri Kontrol Sistemleri Tic. Ltd.  
 Sti.  
**TR-06810 Ankara**  
 Tel +90 312 217 32 88  
 Fax +90 312 217 33 88  
 megaendustri@megaendustri.com.tr  
 www.megaendustri.com.tr

CTS Control Limited Liability Company  
**UA-02099 Kiyiv**  
 Tel +38 044 566-9971, -8427  
 Fax +38 044 566-9384  
 v\_polyakov@cts.com.ua

## Africa

AUMA South Africa (Pty) Ltd.  
**ZA-1560 Springs**  
 Tel +27 11 3632880  
 Fax +27 11 8185248  
 aumasa@mweb.co.za

A.T.E.C.  
**EG- Cairo**  
 Tel +20 2 23599680 - 23590861  
 Fax +20 2 23586621  
 atec@intouch.com

## America

AUMA ACTUATORS INC.  
**US-PA 15317 Canonsburg**  
 Tel +1 724-743-AUMA (2862)  
 Fax +1 724-743-4711  
 mailbox@auma-usa.com  
 www.auma-usa.com

AUMA Argentina Representative Office  
**AR-Boulogne**  
 Tel/Fax +54 232 246 2283  
 contacto@aumaargentina.com.ar

AUMA Automação do Brasil Ltda.  
**BR-Sao Paulo**  
 Tel +55 11 8114-6463  
 bitzco@uol.com.br

AUMA Chile Representative Office  
**CL-9500414 Buin**  
 Tel +56 2 821 4108  
 Fax +56 2 281 9252  
 aumachile@adsl.tie.cl

TROY-ONTOR Inc.  
**CA-L4N 8X1 Barrie Ontario**  
 Tel +1 705 721-8246  
 Fax +1 705 721-5851  
 troy-ontor@troy-ontor.ca

MAN Ferrostaal de Colombia Ltda.  
**CO- Bogotá D.C.**  
 Tel +57 1 401 1300  
 Fax +57 1 416 5489  
 dorian.hernandez@manferrostaal.com  
 www.manferrostaal.com

PROCONTIC Procesos y Control Automático  
**EC- Quito**  
 Tel +593 2 292 0431  
 Fax +593 2 292 2343  
 info@procontic.com.ec

Corsusa International S.A.C.  
**PE- Miraflores - Lima**  
 Tel +511444-1200 / 0044 / 2321  
 Fax +511444-3664  
 corsusa@corsusa.com  
 www.corsusa.com

PASSCO Inc.  
**PR-00936-4153 San Juan**  
 Tel +18 09 78 77 20 87 85  
 Fax +18 09 78 77 31 72 77  
 Passco@prtc.net

Suplibarca  
**VE- Maracaibo Estado, Zulia**  
 Tel +58 261 7 555 667  
 Fax +58 261 7 532 259  
 suplibarca@intercable.net.ve

## Asia

AUMA Actuators (Tianjin) Co., Ltd.  
**CN-300457 Tianjin**  
 Tel +86 22 6625 1310  
 Fax +86 22 6625 1320  
 mailbox@auma-china.com  
 www.auma-china.com

AUMA (INDIA) PRIVATE LIMITED  
**IN-560 058 Bangalore**  
 Tel +91 80 2839 4655  
 Fax +91 80 2839 2809  
 info@auma.co.in  
 www.auma.co.in

AUMA JAPAN Co., Ltd.  
**JP-210-0848 Kawasaki-ku, Kawasaki-shi Kanagawa**  
 Tel +91 80 2839 4655  
 Fax +81 44 366 2472  
 mailbox@auma.co.jp  
 www.auma.co.jp

AUMA ACTUATORS (Singapore) Pte Ltd.  
**SG-569551 Singapore**  
 Tel +65 6 4818750  
 Fax +65 6 4818269  
 sales@auma.com.sg  
 www.auma.com.sg



---

AUMA Actuators Middle East W.L.L.

**AE- 15268 Salmabad 704**

Tel +973 17877377

Fax +973 17877355

Naveen.Shetty@auma.com

PERFECT CONTROLS Ltd.

**HK- Tsuen Wan, Kowloon**

Tel +852 2493 7726

Fax +852 2416 3763

joeip@perfectcontrols.com.hk

DW Controls Co., Ltd.

**KR-153-702 Seoul**

Tel +82 2 2624 3400

Fax +82 2 2624 3401

sichoi@actuatorbank.com

www.actuatorbank.com

Sunny Valves and Intertrade Corp. Ltd.

**TH-10120 Yannawa Bangkok**

Tel +66 2 2400656

Fax +66 2 2401095

sunnyvalves@inet.co.th

www.sunnyvalves.co.th/

Top Advance Enterprises Ltd.

**TW- Jhonghe City Taipei Hsien (235)**

Tel +886 2 2225 1718

Fax +886 2 8228 1975

support@auma-taiwan.com.tw

www.auma-taiwan.com.tw

### **Australia**

BARRON GJM Pty. Ltd.

**AU-NSW 1570 Artarmon**

Tel +61 294361088

Fax +61 294393413

info@barron.com.au

www.barron.com.au

2010-06-17

# auma®

*Solutions for a world in motion*

AUMA Riester GmbH & Co. KG  
P.O.Box 1362  
D-79373 Müllheim  
Tel +49 7631 809 - 0  
Fax+49 7631 809 - 1250  
riester@auma.com  
www.auma.com

