



## Multi-turn gearboxes

GHT 320.3 – GHT 1200.3



**Read operation instructions first.**

- Observe safety instructions.
- These operation instructions are part of the product.
- Retain operation instructions during product life.
- Pass on instructions to any subsequent user or owner of the product.

**Purpose of the document:**

This document contains information for installation, commissioning, operation and maintenance staff. It is intended to support device installation and commissioning.

<b>Table of contents</b>	<b>Page</b>
<b>1. Safety instructions.....</b>	<b>4</b>
1.1. Basic information on safety	4
1.2. Range of application	4
1.3. Warnings and notes	5
1.4. References and symbols	5
<b>2. Identification.....</b>	<b>6</b>
2.1. Name plate	6
2.2. Short description	8
<b>3. Transport, storage and packaging.....</b>	<b>9</b>
3.1. Transport	9
3.2. Storage	10
3.3. Packaging	10
<b>4. Assembly.....</b>	<b>11</b>
4.1. Mounting position	11
4.2. Multi-turn actuators: mount	11
4.3. Gearbox: mount to valve	12
4.3.1. Output drive type A	12
4.3.1.1. Stem nut for output drive type A: finish machining	13
4.3.1.2. Gearbox with output drive type A: mount to valve	14
4.3.2. Output drive type B	15
4.3.2.1. Gearbox with output drive types B: mount to valve	15
4.3.3. Output drive type C	16
4.3.3.1. Gearbox with output drive types C: mount to valve	16
<b>5. Commissioning.....</b>	<b>18</b>
5.1. Test run	18
<b>6. Servicing and maintenance.....</b>	<b>19</b>
6.1. Preventive measures for servicing and safe operation	19
6.2. Maintenance intervals	20
6.3. Disposal and recycling	20
<b>7. Technical data.....</b>	<b>21</b>
7.1. Technical data Multi-turn gearboxes	21
<b>8. Certificates.....</b>	<b>24</b>
8.1. Declaration of Incorporation and EC Declaration of Conformity	24

---

<b>Index.....</b>	<b>25</b>
<b>Addresses.....</b>	<b>26</b>

## 1. Safety instructions

### 1.1. Basic information on safety

<b>Standards/directives</b>	<p>Our products are designed and manufactured in compliance with recognised standards and directives. This is certified in a Declaration of Incorporation and an EC Declaration of Conformity.</p> <p>The end user or the contractor must ensure that all legal requirements, directives, guidelines, national regulations and recommendations with respect to assembly, electrical connection, commissioning and operation are met at the place of installation.</p>
<b>Safety instructions/warnings</b>	<p>All personnel working with this device must be familiar with the safety and warning instructions in this manual and observe the instructions given. Safety instructions and warning signs on the device must be observed to avoid personal injury or property damage.</p>
<b>Qualification of staff</b>	<p>Assembly, electrical connection, commissioning, operation, and maintenance must be carried out exclusively by suitably qualified personnel having been authorised by the end user or contractor of the plant only.</p> <p>Prior to working on this product, the staff must have thoroughly read and understood these instructions and, furthermore, know and observe officially recognised rules regarding occupational health and safety.</p> <p>Work performed in potentially explosive atmospheres is subject to special regulations which have to be observed. The end user or contractor of the plant are responsible for respect and control of these regulations, standards, and laws.</p>
<b>Commissioning</b>	<p>Prior to commissioning, it is important to check that all settings meet the requirements of the application. Incorrect settings might present a danger to the application, e.g. cause damage to the valve or the installation. The manufacturer will not be held liable for any consequential damage. Such risk lies entirely with the user.</p>
<b>Operation</b>	<p>Prerequisites for safe and smooth operation:</p> <ul style="list-style-type: none"> <li>• Correct transport, proper storage, mounting and installation, as well as careful commissioning.</li> <li>• Only operate the device if it is in perfect condition while observing these instructions.</li> <li>• Immediately report any faults and damage and allow for corrective measures.</li> <li>• Observe recognised rules for occupational health and safety.</li> <li>• Observe the national regulations.</li> <li>• During operation, the device warms up and increased surface temperature may occur. To prevent possible burns, we recommend checking the surface temperature using an appropriate thermometer and wearing protective gloves, if required, prior to working on the device.</li> </ul>
<b>Protective measures</b>	<p>The end user or the contractor are responsible for implementing required protective measures on site, such as enclosures, barriers, or personal protective equipment for the staff.</p>
<b>Maintenance</b>	<p>To ensure safe device operation, the maintenance instructions included in this manual must be observed.</p> <p>Any device modification requires prior consent of the manufacturer.</p>

### 1.2. Range of application

AUMA multi-turn gearboxes are designed for the operation of industrial valves, e.g. gate valves and globe valves.

Other applications require explicit (written) confirmation by the manufacturer.

The following applications are not permitted, e.g.:

- Industrial trucks according to EN ISO 3691

- Lifting appliances according to EN 14502
- Passenger lifts according to DIN 15306 and 15309
- Service lifts according to EN 81-1/A1
- Escalators
- Radiation exposed areas in nuclear power plants

No liability can be assumed for inappropriate or unintended use.

Observance of these operation instructions is considered as part of the device's designated use.

### 1.3. Warnings and notes

The following warnings draw special attention to safety-relevant procedures in these operation instructions, each marked by the appropriate signal word (DANGER, WARNING, CAUTION, NOTICE).



Indicates an imminently hazardous situation with a high level of risk. Failure to observe this warning could result in death or serious injury.



Indicates a potentially hazardous situation with a medium level of risk. Failure to observe this warning could result in death or serious injury.



Indicates a potentially hazardous situation with a low level of risk. Failure to observe this warning may result in minor or moderate injury. May also be used with property damage.



Potentially hazardous situation. Failure to observe this warning may result in property damage. Is not used for personal injury.

#### Arrangement and typographic structure of the warnings



#### Type of hazard and respective source!

*Potential consequence(s) in case of non-observance (option)*

- Measures to avoid the danger
- Further measure(s)

Safety alert symbol  warns of a potential personal injury hazard.

The signal word (here: DANGER) indicates the level of hazard.

### 1.4. References and symbols

The following references and symbols are used in these instructions:

**Information** The term **Information** preceding the text indicates important notes and information.

 Symbol for CLOSED (valve closed)

 Symbol for OPEN (valve open)

✓ Important information before the next step. This symbol indicates what is required for the next step or what has to be prepared or observed.

<> **Reference to other sections**

Terms in brackets shown above refer to other sections of the document which provide further information on this topic. These terms are either listed in the index, a heading or in the table of contents and may quickly be found.

## 2. Identification

### 2.1. Name plate

Figure 1: Arrangement of name plates

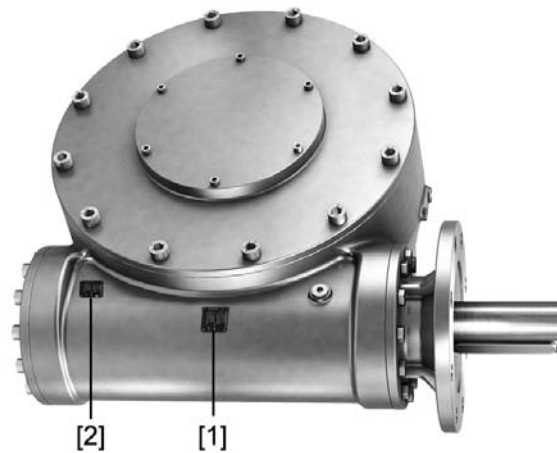

- [1] Gearbox name plate
- [2] Additional plate, e.g. KKS plate (Power Plant Classification System)

### Description of gearbox name plate

Figure 2: Gearbox name plate (example)

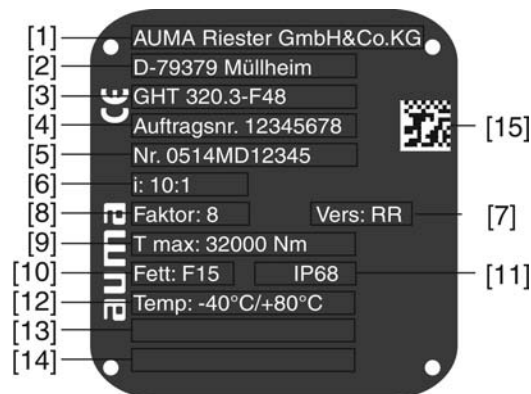

- [1] Name of manufacturer
- [2] Address of manufacturer
- [3] **Type designation**
- [4] **Order number**
- [5] **Serial number**
- [6] **Reduction ratio**
- [7] **Version**
- [8] **Factor**
- [9] **Max. output torque**
- [10] Lubricant
- [11] Enclosure protection
- [12] Ambient temperature range
- [13] Explosion-proof version (option)
- [14] Customer information (option)
- [15] **Data Matrix code**

**Type designation** Figure 3: Type designation (example)

**GHT 320 - F48**

↑ 1.      ↑ 2.

1. Gearbox type and size (z.B. 320 ≙ 32,000 Nm)
2. Output drive flange size

**Type and size**

These instructions apply to the following devices types and sizes:

GHT multi-turn gearbox (**Gearbox High Torque**): 320.3, 500.3, 800.3, 1200.3

**Order number** The product can be identified using this number and the technical data as well as order-related data pertaining to the device can be compiled.

Please always state this number for any product inquiries.

On the Internet at <http://www.auma.com>, we offer a service allowing authorised users to download order-related documents such as wiring diagrams and technical data (both in German and English), inspection certificates and the operation instructions when entering the order number.

**Serial number** Table 1: Description of serial number (with example)

<b>05</b>	<b>14</b>	<b>MD12345</b>
<b>1<sup>st</sup>+2<sup>nd</sup> position: Assembly in week</b>		
05	Week 05	
<b>3<sup>rd</sup>+4<sup>th</sup> position: Year of production</b>		
	14	Year of production: 2014
<b>All other positions</b>		
	MD12345	Internal number for unambiguous product identification

**Reduction ratio** The reduction ratio within gearing reduces the required input torques and increases the operating time.

**Version** Figure 4: Version (worm shaft position and direction of rotation)

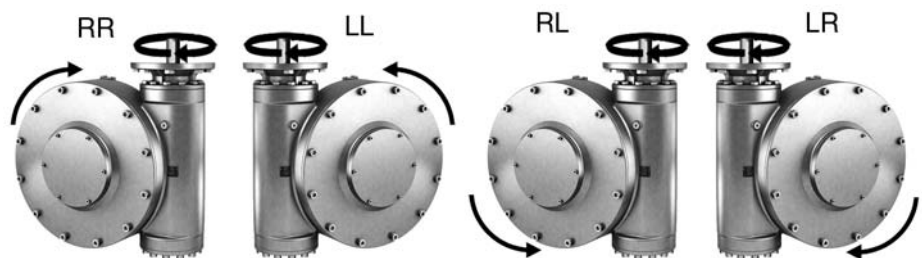

The first letter of the version indicates the **position of the worm shaft** in relation to the worm wheel (view on input shaft).

The second letter indicates the **direction of rotation** of the valve shaft (view on housing cover) for clockwise rotation at the input shaft.

Table 2: Version

Version	Position of worm shaft	Rotation direction of valve shaft
RR	right	clockwise
LL	left	counterclockwise
RL	right	counterclockwise
LR	left	clockwise

**Factor** Mechanical gearbox factor to determine the actuator size: Input torque = required output torque/factor

**Output torque** T<sub>max.</sub> = max. achievable/missible output torque (valve torque) at valve attachment (output drive shaft of gearbox)

**Data Matrix code** When registered as authorised user, you may use the **AUMA Support App** to scan the Data Matrix code and directly access the order-related product documents without having to enter order number or serial number.

Figure 5: Link to the App store:



## 2.2. Short description

This gearbox is used to generate a rotating movement and is appropriate for industrial plants.

The gearbox is motor-driven via a multi-turn actuator. In combination with an AUMA multi-turn actuator, output torques up to 120,000 Nm can be reached.



### 3. Transport, storage and packaging

#### 3.1. Transport

For transport to place of installation, use sturdy packaging.

Transport gearbox and actuator separately.

**DANGER**

#### Hovering load!

*Death or serious injury possible.*

- Do NOT stand below hovering load.
- Check eyebolts for tight seat in housing (verify reach of the screw).
- Respect total weight of combination (gearbox, actuator, ...).
- Eyebolts are only specified for the total gearbox weight. Prior to transport, remove any mounted components like output drive type A or actuator.

Figure 6: Fixture using 4 M36 eyebolts

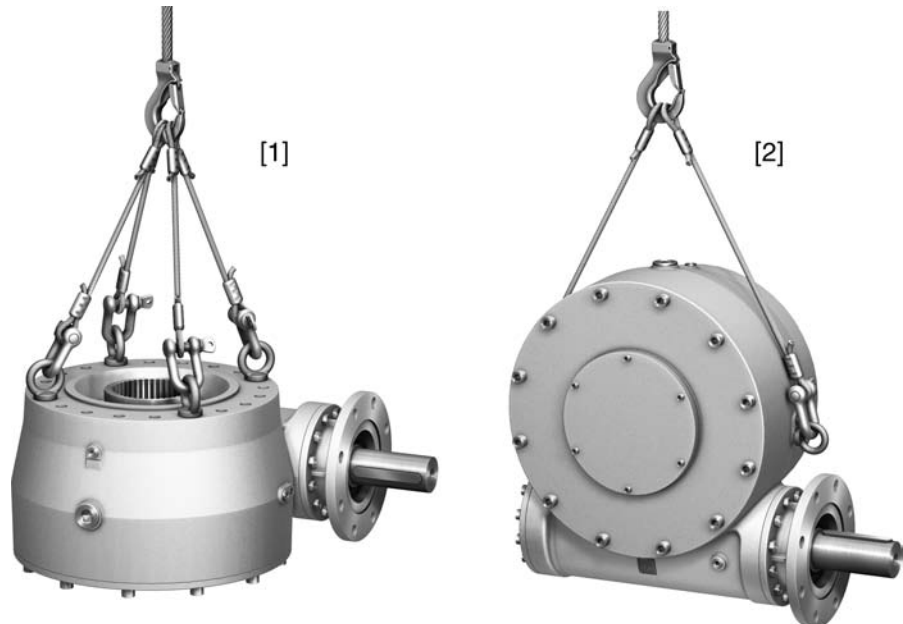

[1] Fixture for horizontal transport

[2] Fixture for vertical transport

**Information** Supporting strength of eyebolts depend on angle of traction and the screw positions (lateral or top).

Table 3: Weight including output mounting flange

Type	Total weight in kg <sup>1)</sup>
GHT 320.3-F48	477
GHT 500.3-F60	765
GHT 800.3-F60	995
GHT 1200.3-F60	1 280

1) With one drive shaft end, output drive type B, largest output drive flange with standard lubricant.

### 3.2. Storage

**NOTICE****Danger of corrosion due to inappropriate storage!**

- Store in a well-ventilated, dry room (maximum humidity 70 %).
- Protect against floor dampness by storage on a shelf or on a wooden pallet.
- Cover to protect against dust and dirt.
- Apply suitable corrosion protection agent to uncoated surfaces.

**Long-term storage**

If the device must be stored for a long period (more than 6 months) the following points must be observed in addition:

1. Prior to storage:  
Protect uncoated surfaces, in particular the output drive parts and mounting surface, with long-term corrosion protection agent.
2. At an interval of approx. 6 months:  
Check for corrosion. If first signs of corrosion show, apply new corrosion protection.

### 3.3. Packaging

Our products are protected by special packaging for transport when leaving the factory. The packaging consists of environmentally friendly materials which can easily be separated and recycled. We use the following packaging materials: wood, cardboard, paper, and PE foil. For the disposal of the packaging material, we recommend recycling and collection centres.

## 4. Assembly

### 4.1. Mounting position

The gearboxes described here can be operated without restriction in any mounting position.

### 4.2. Multi-turn actuators: mount

Refer to the operation instructions pertaining to the multi-turn actuator for indications on how to mount multi-turn actuators to gearboxes.

This chapter supplies basic information and instructions which should be considered in addition to the operation instructions of the multi-turn actuator.

Figure 7: Mounting example: AUMA multi-turn actuator SA 25.1 with GHT 320.3



### Multi-turn actuators and flanges

Table 4: Suitable multi-turn actuators and input mounting flanges

Type Gearboxes	Input mounting flanges for mounting multi-turn actuators	Permissible actuator weight	Suitable AUMA multi-turn actuator
	EN ISO 5210	max.	
GHT 320.3	F25, F30	260	SA/SAR 25.1 / SA/SAR 30.1
GHT 500.3	F30, F35	425	SA/SAR 30.1 / SA 35.1
GHT 800.3	F35, F40	510	SA 35.1
GHT 1200.3	F35, F40	510	SA 35.1 / SA 40.1

### Screws to actuator

Screws are included in the scope of delivery of the gearbox for mounting AUMA multi-turn actuators. When mounting other actuators, the screws might be either too long or too short (insufficient reach of screws).



**Risk of actuator falling off in case inappropriate screws used should shear.**

*Risk of death or serious injury!*

→ Check length of screws.

→ Only use screws with strength class specified herein.

The reach of screws must be sufficient for the internal threads to ensure the supporting strength of the device and to accept the lateral forces due to the applied torque.

Screws which are too long could make contact with the housing parts, presenting the risk that the device performs a radial shift with respect to the gearbox. This can lead to shearing of the screws.

Table 5: Tightening torques for screws  
(for mounting multi-turn actuator and input mounting flange)

Screws Threads	Tightening torque $T_A$ [Nm]
	Strength class A2-80 Geomet
M8	24
M10	48
M12	82
M16	200
M20	392

- Torque switching**
- The setting of the torque switching within the multi-turn actuator may not exceed the max. permissible input torque for both directions (refer to technical data or name plate).
  - Set the torque switching within the multi-turn actuator to the following value to prevent any damage to the valve:  
 $T_{\text{torque switch}} = T_{\text{valve}} / \text{factor}$   
 Factor = Conversion factor from output torque to input torque. Values are specified in the technical data section.

**4.3. Gearbox: mount to valve**

**NOTICE**

**Danger of corrosion due to damage to paint finish!**

→ Touch up damage to paint finish after work on the device.

**4.3.1. Output drive type A**

- Application**
- Output drive for rising, non-rotating valve stem
  - Capable of withstanding thrust

**Design** Torque is transmitted by means of a stem nut.

Figure 8: Design of output drive type A

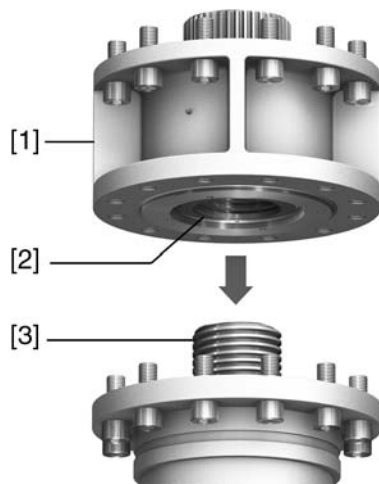

- [1] Output drive type A
- [2] Stem nut with splines
- [3] Stem

#### 4.3.1.1. Stem nut for output drive type A: finish machining

- ✓ This working step is only required if stem nut is supplied unbored or with pilot bore.

Figure 9: Design output drive type A, example A 48.2

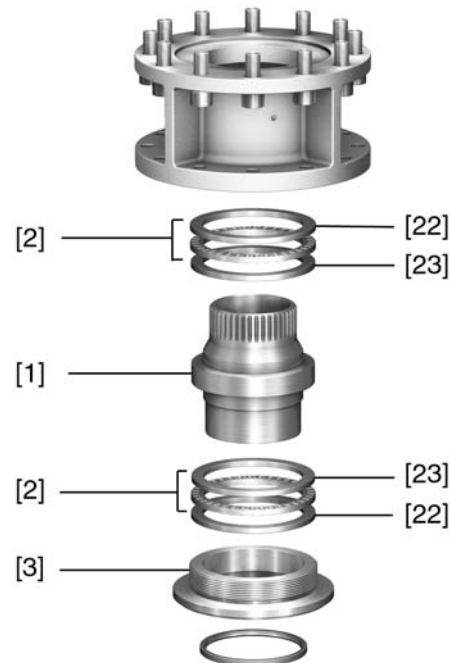

- [1] Stem nut
- [2] Axial cylinder roller bearing
- [22] Housing washer
- [23] Thrust bearing race
- [3] Spigot ring

1. Remove spigot ring [3] from output drive.
2. Remove stem nut [1] together with axial cylinder roller bearing [2].  
**Information:** Record the order of the bearing races [22/23].
3. Remove axial cylinder roller bearing [2] from stem nut [1].
4. Drill and bore stem nut and cut thread.  
**Information:** When fixing in the chuck, make sure stem nut runs true!
5. Clean the machined stem nut.
6. Apply Lithium soap EP multi-purpose grease to axial cylinder roller bearings [2], then place them on stem nut.  
**Information:** Respect correct order of bearing races [22/23].
7. Re-insert stem nut [1] with axial cylinder roller bearing [2] into output drive.  
**Information:** Ensure that dogs or splines are placed correctly in the keyway of the hollow shaft.
8. Screw in spigot ring until it is firm against the shoulder.

9. Press in Lithium soap EP multi-purpose grease on mineral oil base at the grease nipple with a grease gun.

Table 6: Grease quantities for bearing of output drive type A

Output drive type	A 48.2	A 60.2
Quantity [g] <sup>1)</sup>	150	1,000

1) For grease with density  $r = 0.9 \text{ kg/dm}^3$

#### 4.3.1.2. Gearbox with output drive type A: mount to valve

Figure 10: Assembly of output drive type A

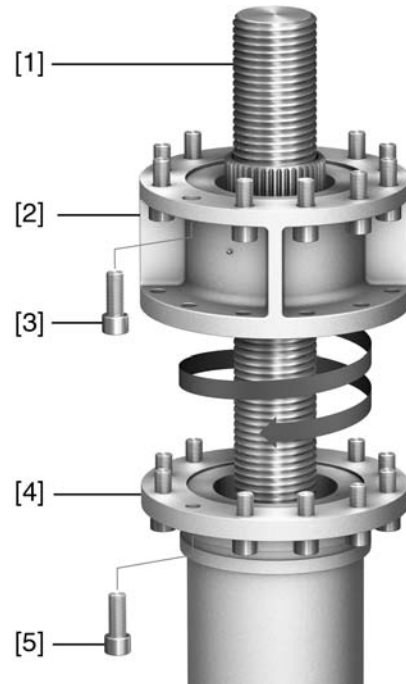

- [1] Valve stem
- [2] Output drive type A
- [3] Screws to gearbox
- [4] Valve flange
- [5] Screws to output drive

1. If output drive type A is already mounted to the gearbox: Loosen screws [3] and remove output drive type A [2].
2. Check if the flange of output drive type A matches the valve flange [4].
3. Apply a small quantity of grease to the valve stem [1].
4. Place output drive type A on valve stem and turn until it is flush on the valve flange.
5. Turn output drive type A until alignment of the fixing holes.
6. Screw in fastening screws [5], however do not completely tighten.
7. Fit gearbox on the valve stem so that the stem nut dogs engage into the output drive sleeve.
- ➔ The flanges are flush with each other if properly engaged.
8. Adjust gearbox until alignment of the fixing holes.
9. Fasten gearbox with screws [3].

10. Fasten screws [3] crosswise with a torque according to table.

Table 7: Tightening torques for screws

Screws	Tightening torque $T_A$ [Nm]
Threads	Strength class 8.8 Geomet 500
M36	2,594

11. Turn gearbox with handwheel in direction OPEN until valve flange and output drive type A are firmly placed together.

12. Tighten fastening screws [5] between valve and output drive type A crosswise applying a torque according to table.

#### 4.3.2. Output drive type B

- Application**
- For rotating, non-rising valve stem
  - Not capable of withstanding thrust

**Design** Output drive type B with bore and keyway

Figure 11: Output drive type B

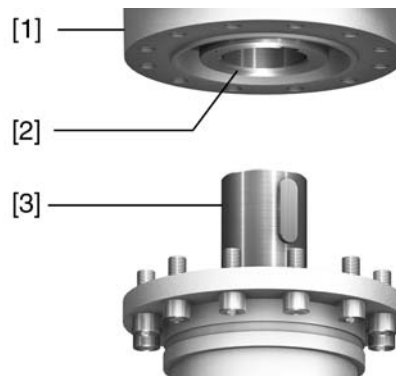

- [1] Gearing flange  
 [2] Hollow shaft with keyway  
 [3] Valve shaft with spring

**Information** Spigot at valve flanges should be loose fit.

##### 4.3.2.1. Gearbox with output drive types B: mount to valve

Figure 12: Mounting output drive types B

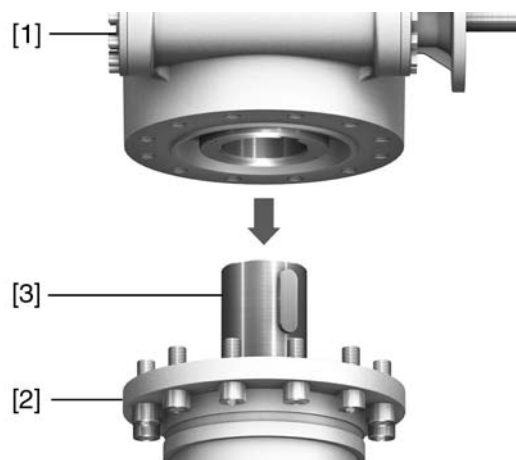

- [1] GHT gearbox  
 [2] Valve  
 [3] Valve shaft

1. Check if mounting flanges fit together.

2. Check, if output drive of gearbox [2] matches the output drive of valve/valve shaft [2/3].
3. Apply a small quantity of grease to the valve shaft [3].
4. Fit gearbox [1].  
**Information:** Ensure that the spigot fits uniformly in the recess and that the mounting faces are in complete contact.
5. Fasten gearbox with screws.  
**Information:** We recommend applying liquid thread sealing material to the screws to avoid contact corrosion.
6. Fasten screws crosswise to a torque according to table.

Table 8: Tightening torques for screws

Screws	Tightening torque $T_A$ [Nm]
Threads	Strength class 8.8 Geomet 500
M36	2,594

### 4.3.3. Output drive type C

- Application**
- For rotating, non-rising valve stem
  - Not capable of withstanding thrust

**Design** Output drive type C (EN ISO 5210/DIN 3210) with dog coupling according to DIN 3338

Figure 13: Output drive type C

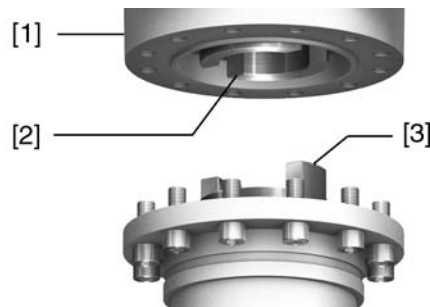

- [1] Gearing flange
- [2] Hollow shaft with dog coupling
- [3] Valve shaft with dog coupling

**Information** Spigot at valve flanges should be loose fit.

#### 4.3.3.1. Gearbox with output drive types C: mount to valve

Figure 14: Mounting output drive types C

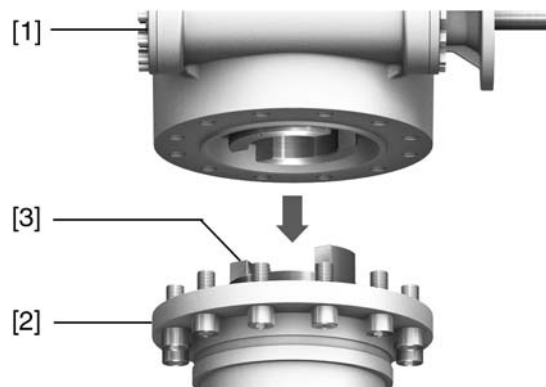

- [1] GHT gearbox
- [2] Valve
- [3] Valve shaft



1. Check if mounting flanges fit together.
2. Check, if output drive of gearbox [2] matches the output drive of valve/valve shaft [2/3].
3. Apply a small quantity of grease to the valve shaft [3].
4. Fit gearbox [1].  
**Information:** Ensure that the spigot fits uniformly in the recess and that the mounting faces are in complete contact.
5. Fasten gearbox with screws.  
**Information:** We recommend applying liquid thread sealing material to the screws to avoid contact corrosion.
6. Fasten screws crosswise to a torque according to table.

Table 9: Tightening torques for screws

Screws	Tightening torque $T_A$ [Nm]
Threads	Strength class 8.8 Geomet 500
M36	2,594

## 5. Commissioning

### 5.1. Test run

1. Run gearbox at partial load for several minutes.



---

**Risk of gear damage if running time is exceeded!**

- Heed actuator operation mode (e.g. S2 - 15 min).

2. Perform functional test observing the following points:
  - Unusual noise
  - Vibration
  - Smoke and steam formation



---

**Risk of gearbox damage in case of obvious malfunctions!**

- Shut down gearbox.
- Consult AUMA service.

3. Check gearbox for tightness after functional operation.

## 6. Servicing and maintenance

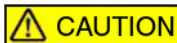

### Damage caused by inappropriate maintenance!

- Servicing and maintenance must be carried out exclusively by suitably qualified personnel having been authorised by the end user or the contractor of the plant. Therefore, we recommend contacting our service.
- Only perform servicing and maintenance tasks when the device is switched off.

### AUMA Service & Support

AUMA offer extensive service such as servicing and maintenance as well as customer product training. For the relevant contact addresses, please refer to <Addresses> in this document or to the Internet (www.auma.com).

### 6.1. Preventive measures for servicing and safe operation

The following actions are required to ensure safe device operation:

#### Every 3 months after commissioning

Check the gearbox for lubricant leakage.

#### Every 6 months after commissioning

- Visual inspection for:
  - Lubricant leakage
  - Unusual noise
  - Vibration
- When rarely operated: Perform test run.
- For devices with output drive type A: Press in Lithium soap EP multi-purpose grease on mineral oil base at the grease nipple with a grease gun.
- Lubrication of the valve stem must be done separately.

Figure 15: Output drive type A



- [1] Output drive type A
- [2] Grease nipple

Table 10: Grease quantities for bearing of output drive type A

Output drive type	A 48.2	A 60.2
Quantity [g] <sup>1)</sup>	150	1,000

1) For grease with density  $\rho = 0.9 \text{ kg/dm}^3$

#### Every 6 months after commissioning and then once a year

- Check fastening screws between actuator, gearbox and valve for tightness. If required, fasten screws while applying the tightening torques as indicated in chapter <Assembly>.
- Clean gearbox if required.

#### Every 5 years after commissioning

- Test gearbox function in detail. Record the results for future reference.

## 6.2. Maintenance intervals

- The gearbox is lubricated for life.
- Generally, the lubricant filling level should be checked every 6 months.

Figure 16: Inspecting/refilling lubricant

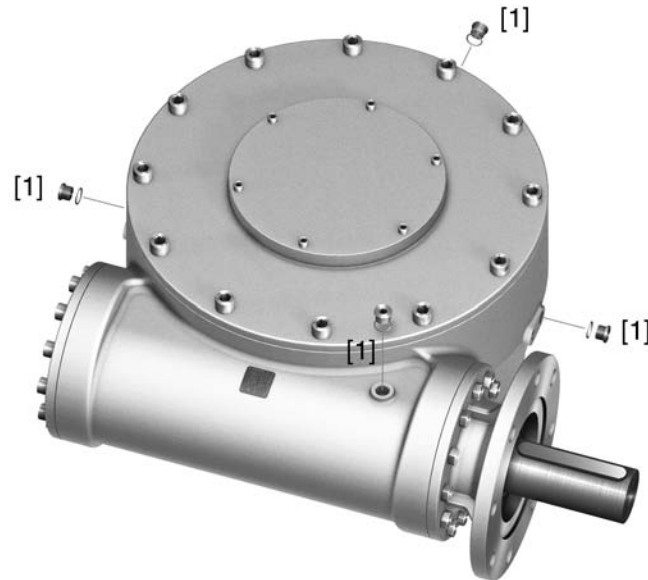

[1] Screw plugs

### NOTICE

#### Gearing damage due to inappropriate grease!

- Only use original lubricants.
- The lubricant type is marked on the name plate.
- Do not mix lubricants.

## 6.3. Disposal and recycling

Our devices have a long lifetime. However, they have to be replaced at one point in time. The devices have a modular design and may, therefore, easily be separated and sorted according to materials used, i.e.:

- electronic scrap
- various metals
- plastics
- greases and oils

The following generally applies:

- Greases and oils are hazardous to water and must not be released into the environment.
- Arrange for controlled waste disposal of the disassembled material or for separate recycling according to materials.
- Observe the national regulations for waste disposal.

## 7. Technical data

**Information** The following technical data includes standard and optional features. For detailed information on the customer-specific version, refer to the order-related data sheet. The technical data sheet can be downloaded from the Internet at [www.auma.com](http://www.auma.com) in both German and English (please state the order number).

### 7.1. Technical data Multi-turn gearboxes

Type	Valve attachment	Reduction ratio	Factor <sup>1)</sup>	Max. input speed	Load profile/torque curve according to EN 15714/-2			Load profile/torque curve for special valves	
					Output torque <sup>2)</sup>	Run torque <sup>3)</sup>	Input torque <sup>4)</sup>	Run torque <sup>5)</sup>	Input torque <sup>6)</sup>
	Flange according to EN ISO 5210			[rpm]	Max. [Nm]	[Nm]	Max. [Nm]	Max. [Nm]	Max. [Nm]
GHT 320.3	F48	10 : 1	8	90	32,000	11,200	4,000	20,800	2,600
		15.5 : 1	12.48				2,600		1,680
		20 : 1	16				2,000		1,300
GHT 500.3	F60	10.25 : 1	8.2		50,000	17,500	6,100	32,500	3,960
		15 : 1	12				4,200		2,710
		20.5 : 1	16.4				3,100		1,980
GHT 800.3	F60	12 : 1	9.6		80,000	28,000	8,300	51,900	5,410
		15 : 1	12				6,700		4,330
GHT 1200.3	F60	10.25 : 1	8.2		120,000	42,000	14,600	77,900	9,500
		20.5 : 1	16.4				7,300		4,750

1) Conversion factor from output torque to input torque for actuator size definition

2) Maximum 10 % of the travel (25 turns per stroke)

3) 90 % of travel

4) For maximum output torque

5) 100 % of travel

6) Verify actuator sizing for running times > 2 minutes and high output speeds. For long running times, the output torques of the actuators will be reduced.

Possible combinations with multi-turn actuators													
Type	Reduction ratio	Factor <sup>1)</sup>	Suitable AUMA multi-turn actuator for	Output speed in rpm for multi-turn actuator speed of 50 Hz									
				100 % Output torque									
				4	5.6	8	11	16	22	32	45	63	90
GHT 320.3	10 : 1	8	SA 30.1	0.4	0.6	0.8	1.1	1.6	2.2	3.2	4.5	6.3	9.0
	15.5 : 1	12.48	SA 25.1	–	0.4	0.5	0.7	1.0	1.4	2.1	2.9	4.1	5.8
	20 : 1	16	SA 25.1	–	–	0.4	0.6	0.8	1.1	1.6	2.3	3.2	4.5
GHT 500.3	10.25 : 1	8.2	SA 35.1	0.4	0.5	0.8	1.1	1.6	2.1	3.1 <sup>2)</sup>	4.4 <sup>2)</sup>	–	–
	15 : 1	12	SA 30.1	–	0.4	0.4	0.7	1.1	1.5	2.1	3.0	4.2	6.0
	20.5 : 1	16.4	SA 30.1	–	0.4	0.4	0.5	0.8	1.1	1.6	2.2	3.1	4.4
GHT 800.3	12 : 1	9.6	SA 35.1	0.3	0.5	0.7	0.9	1.3	1.8	2.7 <sup>2)</sup>	3.8 <sup>2)</sup>	–	–
	15 : 1	12	SA 35.1	–	0.4	0.5	0.7	1.1	1.5	2.1 <sup>2)</sup>	3.0 <sup>2)</sup>	–	–
GHT 1200.3	10.25 : 1	8.2	SA 40.1	0.4	0.5	0.8	1.1	1.6	2.1	3.1 <sup>2)</sup>	–	–	–
	20.5 : 1	16.4	SA 35.1	–	–	0.4	0.5	0.8	1.1	1.6 <sup>2)</sup>	2.2 <sup>2)</sup>	–	–

1) Conversion factor from output torque to input torque for actuator size definition

2) SA not self-locking

## Technical data

Valve attachment options							
Type	Output drive flange to valve Output drive type A/AF	Output drive type B1	Output drive type C	Splined coupling for Output drive type A	Input mounting flanges for mounting AUMA multi-turn actuators	Drive shaft	Weight
	according to EN ISO 5211 <sup>1)</sup>	according to EN ISO 5210	according to DIN 3338	DIN 5480	EN ISO 5210	EN ISO 5210 [Ø]	[kg] <sup>2)</sup>
<b>GHT 320.3</b>	F48	Ø 180H7 mm with parallel key according to DIN 6885	$d_{12} = \text{Ø } 259$ mm	N210x5x40	F25, F30	60	477
<b>GHT 500.3</b>	F60		$d_{11} = \text{Ø } 180$ mm	N220x5x42	F30, F35	80	765
<b>GHT 800.3</b>	F60		$b_1 = 85$ mm		F35, F40	100	995
<b>GHT 1200.3</b>	F60		$h_{11} = 50$ mm		F35, F40	100	1,280

1) Dimension according to EN ISO 5211

2) Indicated weight includes gearbox with a drive shaft end, output drive type B, largest possible input mounting flange, including standard lubricant

Use
Worm gearboxes for motor operation of industrial valves (e.g. gate valves and globe valves) and special valves (e.g. louvre dampers, stack dampers, diverters, weirs, and sluice gates).

Features and functions		
Type of duty	Open-close duty:	Short-time duty S2 - 15 min, classes A and B Short-time duty S2 - 30 min, classes A and B
	Modulating duty:	Intermittent duty S4 -25 %, class C; on request
Direction of rotation	Standard:	RR = Clockwise rotation at input shaft results in clockwise rotation at output shaft LR = Clockwise rotation at input shaft results in clockwise rotation at output shaft
	Option:	RL = Clockwise rotation at input shaft results in counterclockwise rotation at output shaft LL = Clockwise rotation at input shaft results in counterclockwise rotation at output shaft
Housing material	Standard:	Cast iron (EN-GJL-250)
	Option:	Spheroidal cast iron (EN-GJS-400-15)
Self-locking	Not self-locking	

Operation	
Self-locking	Directly via electric multi-turn actuator Mounting flanges for multi-turn actuator, refer to table <Torques> and <Valve attachment options>

Service conditions		
Ambient temperature	Standard:	-40 °C to +80 °C
	Options:	-60 °C to +60 °C 0 °C to +140 °C
	For exact version, refer to gearbox name plate.	
Enclosure protection according to EN 60529	IP68	
	Actuator enclosure protection:	
	Standard:	IP67
	Option:	IP68
For exact version, refer to actuator name plate.		
Corrosion protection	Standard:	KN: Suitable for installation in industrial units, in water or power plants with a low pollutant concentration
	Option:	KS: Suitable for use in areas with high salinity, almost permanent condensation, and high pollution.
		KX: Suitable for use in areas with extremely high salinity, permanent condensation, and high pollution.
Paint	Two-component iron-mica combination	

Service conditions		
Colour	Standard:	AUMA silver-grey (similar to RAL 7037)
	Option:	Available colours on request
Lifetime	1,500 cycles AUMA multi-turn gearboxes meet or exceed the lifetime requirements of EN 15714-2. Detailed information can be provided on request.	
Accessories	Stem protection tube, on request 2 eyebolts for transport	

Use in potentially explosive atmospheres		
Explosion protection in accordance with ATEX 94/9/EC	Standard:	II2G c IIC T4 II2D c T130 °C
	Options:	II2G c IIC T3 II2D c T190 °C
	For exact version, refer to gearbox approval plate.	
Ambient temperature	Standard:	–40 °C to +80 °C (II2G c IIC T3; II2D c T190 °C)
	Option:	–40 °C to +60 °C (II2G c IIC T4; II2D c T130 °C)

## 8. Certificates

### 8.1. Declaration of Incorporation and EC Declaration of Conformity

AUMA Riester GmbH & Co. KG  
 Aumastr. 1  
 79379 Müllheim, Germany  
 www.auma.com

Tel +49 7631 809-0  
 Fax +49 7631 809-1250  
 Riester@auma.com



#### Original Declaration of Incorporation of Partly Completed Machinery (EC Directive 2006/42/EC)

for AUMA gearboxes of the type ranges

**Multi-turn gearboxes      GHT 320.3 – GHT 1200.3**

AUMA Riester GmbH & Co. KG as manufacturer declares herewith, that the above mentioned multi-turn gearboxes meet the following basic requirements of the EC Machinery Directive 2006/42/EC: Annex I, articles 1.1.2, 1.1.3, 1.1.5, 1.3.1, 1.3.7, 1.7.1, 1.7.3, 1.7.4

The following harmonised standards within the meaning of the Machinery Directive have been applied:

EN ISO 12100: 2010  
 EN ISO 5210: 1996  
 EN ISO 5211: 2001

With regard to the partly completed machinery, the manufacturer commits to submitting the documents to the competent national authority via electronic transmission upon request. The relevant technical documentation pertaining to the machinery described in Annex VII, part B has been prepared.

AUMA multi-turn gearboxes are designed to be installed on industrial valves. AUMA multi-turn gearboxes must not be put service until the final machinery into which they are to be incorporated has been declared in conformity with the provisions of the EC Directive 2006/42/EC.

Authorised person for documentation: Peter Malus, Aumastrasse 1, D-79379 Müllheim

Müllheim, 2015-01-01

H. Newerla, General Management

This declaration does not contain any guarantees. The safety instructions in product documentation supplied with the devices must be observed. Non-concerted modification of the devices voids this declaration.

Y006.612/003/en



**Index****A**

Ambient temperature	6 , 22
Applications	4
Assembly	11

**C**

Certificates	24
Commissioning	4 , 18
Corrosion protection	10 , 22

**D**

Data Matrix code	8
Declaration of Incorporation	24
Device type	7
Direction of rotation	7 , 22
Directives	4
Disposal	20

**E**

EC Declaration of Conformity	24
Enclosure protection	6 , 22

**F**

Factor	7
Flanges	11
Flange size	7

**I**

Identification	6
Input mounting flanges	11
Inspection record	7

**L**

Lubricants	20
------------	----

**M**

Maintenance	4 , 19
Maintenance intervals	20
Mounting position	11
Multi-turn actuator	11

**N**

Name plate	6
------------	---

**O**

Operation	4
Order number	6 , 7
Output drive type A	12
Output drive type B	15
Output drive type C	16
Output torque	8

**P**

Packaging	10
Production, year	7
Protective measures	4

**Q**

Qualification of staff	4
------------------------	---

**R**

Range of application	4
Recycling	20
Reduction ratio	7

**S**

Safety instructions	4
Safety instructions/warnings	4
Screws	11
Serial number	6 , 7
Service	19
Servicing	19
Size	7
Speed	6
Standards	4
Stem nut	13
Storage	10
Support	19
Support App	8 , 8

**T**

Technical data	21
Torque range	6
Transport	9
Type (device type)	7
Type designation	6
Type of lubricant	6

**V**

Version	7
---------	---

**W**

Wiring diagram	7
----------------	---

**Y**

Year of production	7
--------------------	---

## Europe

**AUMA Riester GmbH & Co. KG**

Plant Müllheim  
**DE 79373 Müllheim**  
 Tel +49 7631 809 - 0  
 riester@auma.com  
 www.auma.com

Plant Ostfildern-Nellingen  
**DE 73747 Ostfildern**  
 Tel +49 711 34803 - 0  
 riester@wof.auma.com

Service-Center Bayern  
**DE 85386 Eching**  
 Tel +49 81 65 9017- 0  
 Riester@scb.auma.com

Service-Center Köln  
**DE 50858 Köln**  
 Tel +49 2234 2037 - 900  
 Service@sck.auma.com

Service-Center Magdeburg  
**DE 39167 Niederrandleben**  
 Tel +49 39204 759 - 0  
 Service@scm.auma.com

AUMA-Armaturentriebe Ges.m.b.H.  
**AT 2512 Tribuswinkel**  
 Tel +43 2252 82540  
 office@auma.at  
 www.auma.at

AUMA BENELUX B.V. B. A.  
**BE 8800 Roeselare**  
 Tel +32 51 24 24 80  
 office@auma.be  
 www.auma.nl

ProStream Group Ltd.  
**BG 1632 Sofia**  
 Tel +359 2 9179-337  
 valtchev@prostream.bg  
 www.prostream.bg

OOO "Dunkan-Privod"  
**BY 220004 Minsk**  
 Tel +375 29 6945574  
 belarus@auma.ru  
 www.zatvor.by

AUMA (Schweiz) AG  
**CH 8965 Berikon**  
 Tel +41 566 400945  
 RettichP.ch@auma.com

AUMA Servopohony spol. s.r.o.  
**CZ 250 01 Brandýs n.L.-St.Boleslav**  
 Tel +420 326 396 993  
 auma-s@auma.cz  
 www.auma.cz

GRØNBECH & SØNNER A/S  
**DK 2450 København SV**  
 Tel +45 33 26 63 00  
 GS@g-s.dk  
 www.g-s.dk

IBEROPLAN S.A.  
**ES 28027 Madrid**  
 Tel +34 91 3717130  
 iberoplan@iberoplan.com

AUMA Finland Oy  
**FI 02230 Espoo**  
 Tel +358 9 5840 22  
 auma@auma.fi  
 www.auma.fi

AUMA France S.A.R.L.  
**FR 95157 Taverny Cedex**  
 Tel +33 1 39327272  
 info@auma.fr  
 www.auma.fr

AUMA ACTUATORS Ltd.  
**GB Clevedon, North Somerset BS21 6TH**  
 Tel +44 1275 871141  
 mail@auma.co.uk  
 www.auma.co.uk

D. G. Bellos & Co. O.E.  
**GR 13673 Acharnai, Athens**  
 Tel +30 210 2409485  
 info@dgbellos.gr

APIS CENTAR d. o. o.  
**HR 10437 Bestovje**  
 Tel +385 1 6531 485  
 auma@apis-centar.com  
 www.apis-centar.com

Fabo Kereskedelmi és Szolgáltató Kft.  
**HU 8800 Nagykanizsa**  
 Tel +36 93/324-666  
 auma@fabo.hu  
 www.fabo.hu

Falkinn HF  
**IS 108 Reykjavik**  
 Tel +00354 540 7000  
 os@falkinn.is  
 www.falkinn.is

AUMA ITALIANA S.r.l. a socio unico  
**IT 20023 Cerro Maggiore (MI)**  
 Tel +39 0331 51351  
 info@auma.it  
 www.auma.it

AUMA BENELUX B.V.  
**LU Leiden (NL)**  
 Tel +31 71 581 40 40  
 office@auma.nl

NB Engineering Services  
**MT ZBR 08 Zabbar**  
 Tel + 356 2169 2647  
 nikibel@onvol.net

AUMA BENELUX B.V.  
**NL 2314 XT Leiden**  
 Tel +31 71 581 40 40  
 office@auma.nl  
 www.auma.nl

SIGUM A. S.  
**NO 1338 Sandvika**  
 Tel +47 67572600  
 post@sifag.no

AUMA Polska Sp. z o.o.  
**PL 41-219 Sosnowiec**  
 Tel +48 32 783 52 00  
 biuro@auma.com.pl  
 www.auma.com.pl

AUMA-LUSA Representative Office, Lda.  
**PT 2730-033 Barcarena**  
 Tel +351 211 307 100  
 geral@aumalusa.pt

SAUTECH  
**RO 011783 Bucuresti**  
 Tel +40 372 303982  
 office@sautech.ro

OOO PRIWODY AUMA  
**RU 141402 Khimki, Moscow region**  
 Tel +7 495 221 64 28  
 aumarussia@auma.ru  
 www.auma.ru

OOO PRIWODY AUMA  
**RU 125362 Moscow**  
 Tel +7 495 787 78 21  
 aumarussia@auma.ru  
 www.auma.ru

ERICHs ARMATUR AB  
**SE 20039 Malmö**  
 Tel +46 40 311550  
 info@erichsarmatur.se  
 www.erichsarmatur.se

ELSO-b, s.r.o.  
**SK 94901 Nitra**  
 Tel +421 905/336-926  
 elsob@stonline.sk  
 www.elsob.sk

Auma Endüstri Kontrol Sistemleri Limited  
 Sirketi  
**TR 06810 Ankara**  
 Tel +90 312 217 32 88  
 info@auma.com.tr

AUMA Technology Automations Ltd  
**UA 02099 Kiev**  
 Tel +38 044 586-53-03  
 auma-tech@aumatech.com.ua

## Africa

Solution Technique Contrôle Commande  
**DZ Bir Mourad Rais, Algiers**  
 Tel +213 21 56 42 09/18  
 stcco@wissal.dz

A.T.E.C.  
**EG Cairo**  
 Tel +20 2 23599680 - 23590861  
 contactus@atec-eg.com

SAMIREG  
**MA 203000 Casablanca**  
 Tel +212 5 22 40 09 65  
 samireg@menara.ma

MANZ INCORPORATED LTD.  
**NG Port Harcourt**  
 Tel +234-84-462741  
 mail@manzincorporated.com  
 www.manzincorporated.com

AUMA South Africa (Pty) Ltd.  
**ZA 1560 Springs**  
 Tel +27 11 3632880  
 aumasa@mweb.co.za

## America

AUMA Argentina Rep.Office  
**AR Buenos Aires**  
 Tel +54 11 4737 9026  
 contacto@aumaargentina.com.ar

AUMA Automação do Brazil Ltda.  
**BR Sao Paulo**  
 Tel +55 11 4612-3477  
 contato@auma-br.com

TROY-ONTOR Inc.  
**CA L4N 8X1 Barrie, Ontario**  
 Tel +1 705 721-8246  
 troy-ontor@troy-ontor.ca

AUMA Chile Representative Office  
**CL 9500414 Buin**  
 Tel +56 2 821 4108  
 aumachile@auma-chile.cl

Ferrostaal de Colombia Ltda.  
**CO Bogotá D.C.**  
 Tel +57 1 401 1300  
 dorian.hernandez@ferrostaal.com  
 www.ferrostaal.com

AUMA Región Andina & Centroamérica  
**EC Quito**  
 Tel +593 2 245 4614  
 auma@auma-ac.com  
 www.auma.com

Corsusa International S.A.C.  
**PE Miraflores - Lima**  
 Tel +511444-1200 / 0044 / 2321  
 corsusa@corsusa.com  
 www.corsusa.com

Control Technologies Limited  
**TT Marabella, Trinidad, W.I.**  
 Tel + 1 868 658 1744/5011  
 www.ctltech.com

AUMA ACTUATORS INC.  
**US PA 15317 Canonsburg**  
 Tel +1 724-743-AUMA (2862)  
 mailbox@auma-usa.com  
 www.auma-usa.com

Suplibarca  
**VE Maracaibo, Estado, Zulia**  
 Tel +58 261 7 555 667  
 suplibarca@intercable.net.ve

## Asia

AUMA Actuators UAE Support Office  
**AE 287 Abu Dhabi**  
 Tel +971 26338688  
 Nagaraj.Shetty@auma.com

AUMA Actuators Middle East  
**BH 152 68 Salmabad**  
 Tel +97 3 17896585  
 salesme@auma.com

Mikuni (B) Sdn. Bhd.  
**BN KA1189 Kuala Belait**  
 Tel + 673 3331269 / 3331272  
 mikuni@brunet.bn

AUMA Actuators (China) Co., Ltd  
**CN 215499 Taicang**  
 Tel +86 512 3302 6900  
 mailbox@auma-china.com  
 www.auma-china.com

PERFECT CONTROLS Ltd.  
**HK Tsuen Wan, Kowloon**  
 Tel +852 2493 7726  
 joeip@perfectcontrols.com.hk

PT. Carakamas Inti Alam  
**ID 11460 Jakarta**  
 Tel +62 215607952-55  
 auma-jkt@indo.net.id

AUMA INDIA PRIVATE LIMITED.  
**IN 560 058 Bangalore**  
 Tel +91 80 2839 4656  
 info@auma.co.in  
 www.auma.co.in

ITG - Iranians Torque Generator  
**IR 13998-34411 Teheran**  
 +982144545654  
 info@itg-co.ir

Trans-Jordan Electro Mechanical Supplies  
**JO 11133 Amman**  
 Tel +962 - 6 - 5332020  
 Info@transjordan.net

AUMA JAPAN Co., Ltd.  
**JP 211-0016 Kawasaki-shi, Kanagawa**  
 Tel +81-(0)44-863-8371  
 mailbox@auma.co.jp  
 www.auma.co.jp

DW Controls Co., Ltd.  
**KR 153-702 Gasan-dong, GeumChun-Gu,, Seoul**  
 Tel +82 2 2624 3400  
 import@actuatorbank.com  
 www.actuatorbank.com

Al-Arfaj Engineering Co WLL  
**KW 22004 Salmiyah**  
 Tel +965-24817448  
 info@arfajengg.com  
 www.arfajengg.com

TOO "Armaturny Center"  
**KZ 060005 Atyrau**  
 Tel +7 7122 454 602  
 armacentre@bk.ru

Network Engineering  
**LB 4501 7401 JBEIL, Beirut**  
 Tel +961 9 944080  
 nabil.ibrahim@networkenglb.com  
 www.networkenglb.com

AUMA Malaysia Office  
**MY 70300 Seremban, Negeri Sembilan**  
 Tel +606 633 1988  
 sales@auma.com.my

Mustafa Sultan Science & Industry Co LLC  
**OM Ruwi**  
 Tel +968 24 636036  
 r-negi@mustafasultan.com

FLOWTORK TECHNOLOGIES CORPORATION  
**PH 1550 Mandaluyong City**  
 Tel +63 2 532 4058  
 flowtork@pltdsl.net

M & C Group of Companies  
**PK 54000 Cavalry Ground, Lahore Cantt**  
 Tel +92 42 3665 0542, +92 42 3668 0118  
 sales@mcass.com.pk  
 www.mcass.com.pk

Petrogulf W.L.L.  
**QA Doha**  
 Tel +974 44350151  
 pgulf@qatar.net.qa

AUMA Saudi Arabia Support Office  
**SA 31952 Al Khobar**  
 Tel + 966 5 5359 6025  
 Vinod.Fernandes@auma.com

AUMA ACTUATORS (Singapore) Pte Ltd.  
**SG 569551 Singapore**  
 Tel +65 6 4818750  
 sales@auma.com.sg  
 www.auma.com.sg

NETWORK ENGINEERING  
**SY Homs**  
 +963 31 231 571  
 eyad3@scs-net.org

Sunny Valves and Intertrade Corp. Ltd.  
**TH 10120 Yannawa, Bangkok**  
 Tel +66 2 2400656  
 mainbox@sunnyvalves.co.th  
 www.sunnyvalves.co.th

Top Advance Enterprises Ltd.  
**TW Zhonghe City, Taipei Hsien (235)**  
 Tel +886 2 2225 1718  
 support@auma-taiwan.com.tw  
 www.auma-taiwan.com.tw

AUMA Vietnam Hanoi RO  
**VN Hanoi**  
 +84 4 37822115  
 chiennguyen@auma.com.vn

## Australia

BARRON GJM Pty. Ltd.  
**AU NSW 1570 Artarmon**  
 Tel +61 2 8437 4300  
 info@barron.com.au  
 www.barron.com.au

# **auma**<sup>®</sup>

*Solutions for a world in motion*

## **AUMA Riester GmbH & Co. KG**

P.O.Box 1362

**DE 79373 Muellheim**

Tel +49 7631 809 - 0

Fax +49 7631 809 - 1250

riester@auma.com

www.auma.com



Y006.543/003/en/1.15